



LUEN VALVES

è l'azienda del gruppo
per le valvole idrauliche
e i componenti integrati.

LUEN VALVES

is the group's company
for hydraulic valves
and integrated components.

OMT HYDRAULIC COMPONENTS

è l'azienda del gruppo
per i componenti idraulici.

OMT HYDRAULIC COMPONENTS

is the group's company
for hydraulic components.

**INSIEME NEL SETTORE
DELL'OLEODINAMICA.**

**TOGETHER IN THE
HYDRAULIC INDUSTRY.**

5

MACROGRUPPI DI PRODOTTI

MAIN RANGES OF PRODUCTS

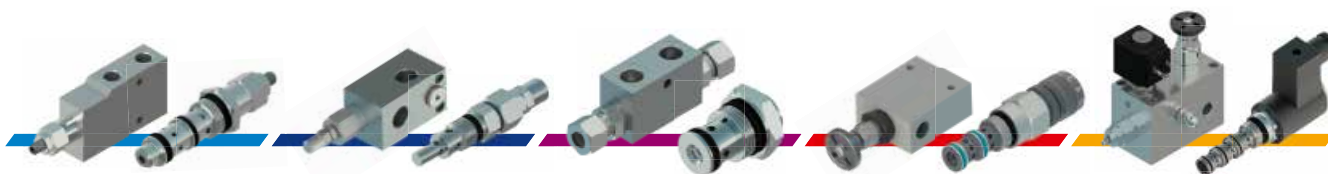

VALVOLE DI
BILANCIAMENTO
E BLOCCO

COUNTERBALANCE
VALVES

VALVOLE DI
MASSIMA
PRESSIONE

RELIEF
VALVES

VALVOLE DI
BLOCCO

CHECK
VALVES

VALVOLE
REGOLATRICI
DI PORTATA

FLOW CONTROL
VALVES

ELETTROVALVOLE
E GRUPPI INTEGRATI

SOLENOID VALVES
AND INTEGRATED
COMPONENTS



VALVOLE
REGOLATRICI DI PORTATA

FLOW CONTROL
VALVES





VALVOLE A CARTUCCIA
CARTRIDGE VALVES

p. 254-265



VALVOLE CON COLLETTORE
VALVES WITH BODY

p. 266-271



VALVOLE DIVISORI/RIUNIFICATORI
FLOW DIVIDER/COMBINER VALVES

p. 272-275



VALVOLE AD INSERTO
INSERT-TYPE VALVES

p. 276-279



VALVOLE A SFERA
BALL VALVES

p. 280-283



VALVOLE DEVIATORI DI FLUSSO
FLOW DIVERTER VALVES

p. 284-289



VALVOLE REGOLATRICI UNIDIREZIONALI
BIDIREZIONALI
UNIDIRECTIONAL BIDIRECTIONAL FLOW CONTROL VALVES

p. 290-297

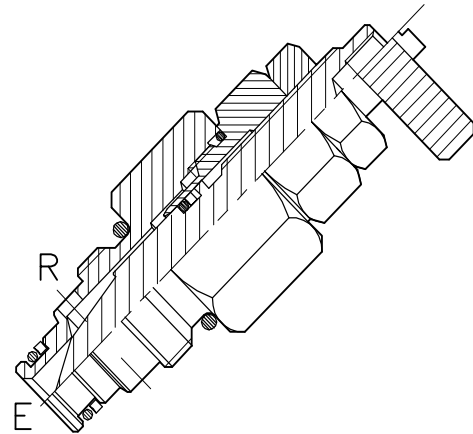
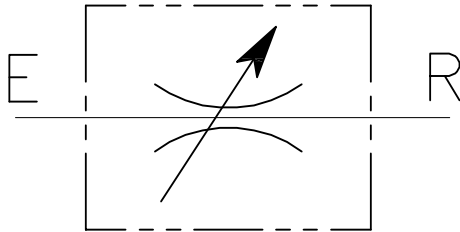

CARATTERISTICHE

Luce nominale	DN 4
Portata min/max	1/20 l/min - 0.26/5.3 GPM
Pressione di lavoro max.	350 bar - 5075 PSI
Temperatura ambiente	-30°C + 50°C
Temperatura olio	-30°C + 80°C
Filtraggio consigliato	30 micron
Coppia di serraggio	46÷54 Nm
Peso	0.137 Kg

PERFORMANCE

Rated size
Min/max flow-rate
Max working pressure
Room temperature
Oil temperature
Recommended filtration
Tightening torque
Weight

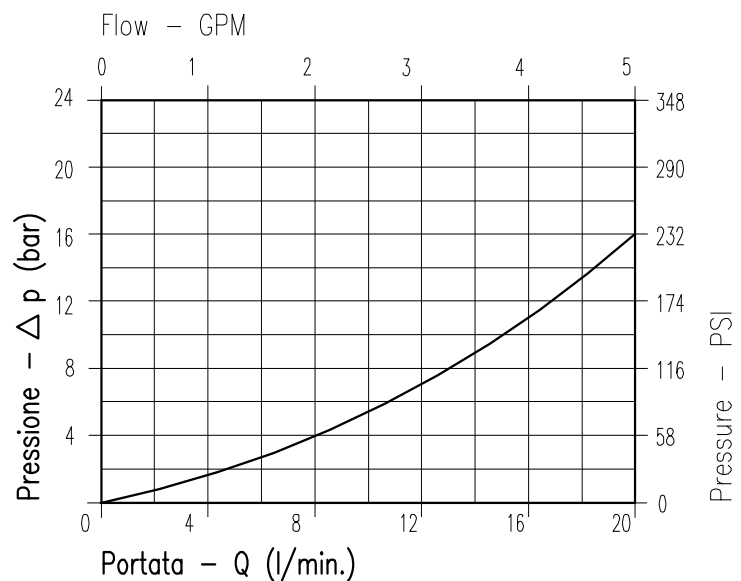

Viscosità olio 46 cSt a 50°C
Oil viscosity 46 cSt at 50°C

VALVOLA REGOLATRICE DI FLUSSO A CARTUCCIA BIDIREZIONALE
CARTRIDGE STYLE FLOW RESTRICTOR VALVE

REGOLAZIONE
ADJUSTMENT

A chiave
Spanner

Volantino
Handknob

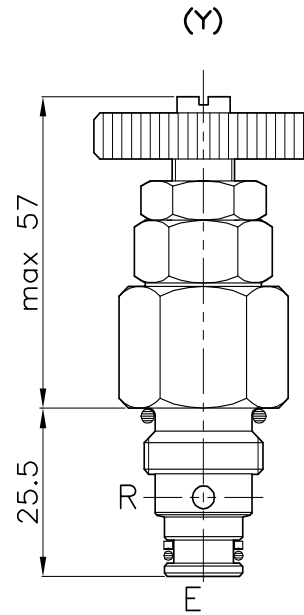
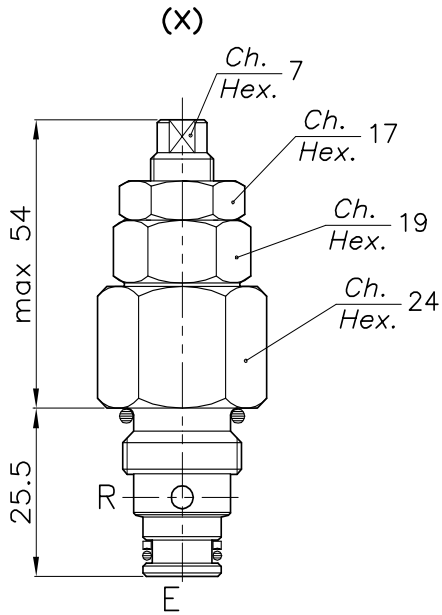

CAVITA'
CAVITY CE.011.N

ESEMPIO TIPICO DI CIRCUITO
TYPICAL CIRCUIT EXAMPLE

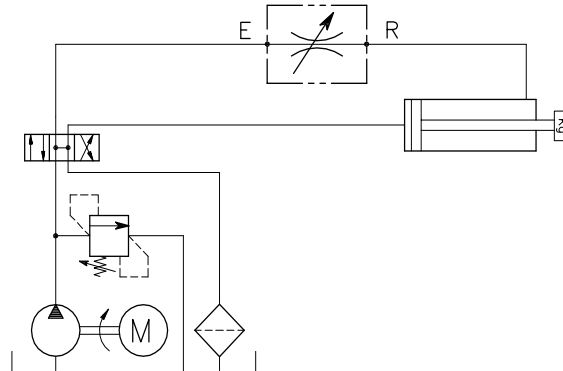
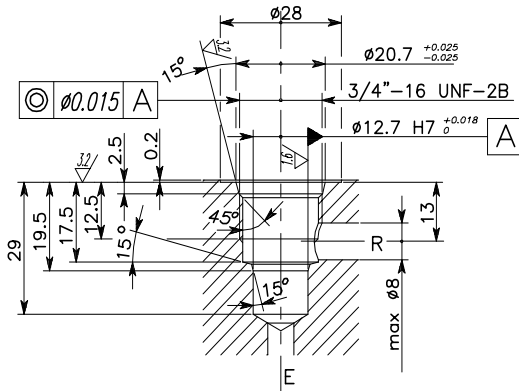

Si raccomanda l'esatta esecuzione della sede
The valve seat should be perfectly tooled

CODICE DI ORDINAZIONE
HOW TO ORDER

004 067 0 X 0

Regolazione
Adjustment
X | A chiave - Spanner
Y | Volantino - handknob

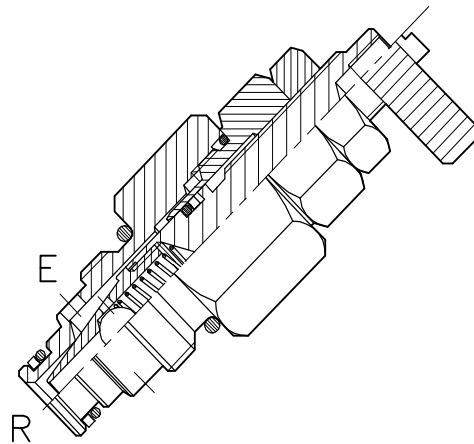
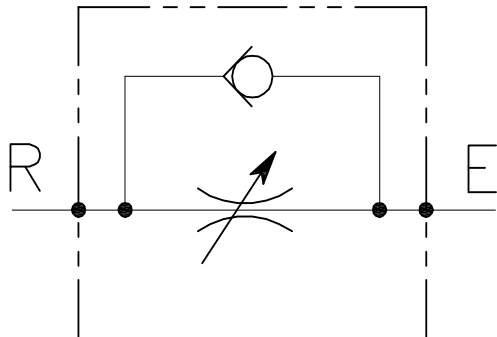

CARATTERISTICHE

Luce nominale	DN 4
Portata min/max	1/20 l/min - 0.26/5.3 GPM
Pressione di lavoro max.	350 bar - 5075 PSI
Temperatura ambiente	-30°C + 50°C
Temperatura olio	-30°C + 80°C
Filtraggio consigliato	50 micron
Coppia di serraggio	46÷54 Nm
Peso	0.133 Kg

PERFORMANCE

Rated size
Min/max flow-rate
Max working pressure
Room temperature
Oil temperature
Recommended filtration
Tightening torque
Weight

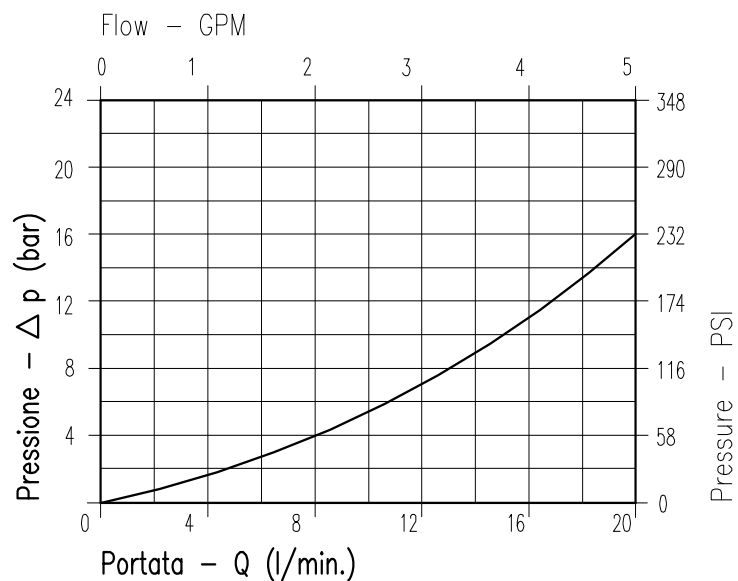

Viscosità olio 46 cSt a 50°C
Oil viscosity 46 cSt at 50°C

VALVOLA REGOLATRICE DI FLUSSO A CARTUCCIA UNIDIREZIONALE
CARTRIDGE STYLE FLOW CONTROL VALVE WITH REVERSE FLOW CHECK

REGOLAZIONE
ADJUSTMENT

A chiave
Spanner
(X)

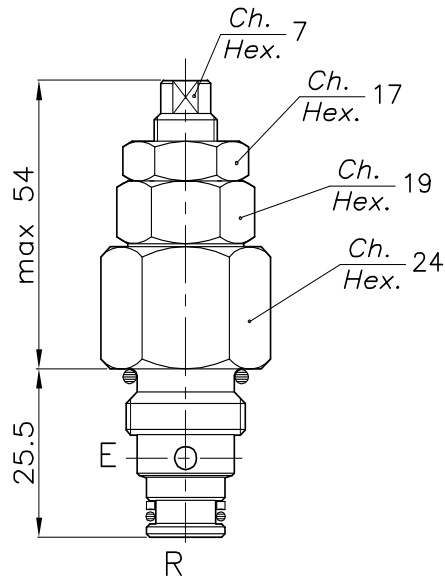

Volantino
Handknob
(Y)

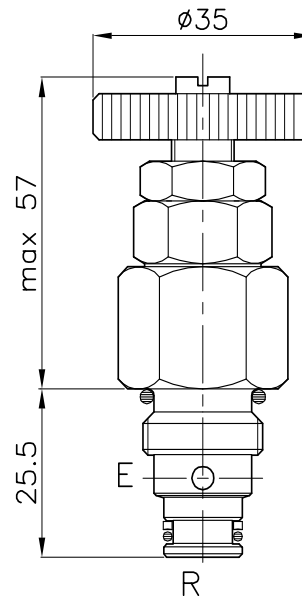

CAVITA' CAVITY CE.011.N

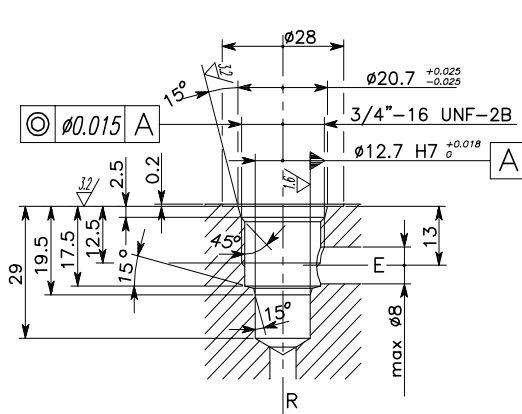

Si raccomanda l'esatta esecuzione della sede
The valve seat should be perfectly tooled

ESEMPIO TIPICO DI CIRCUITO TYPICAL CIRCUIT EXAMPLE

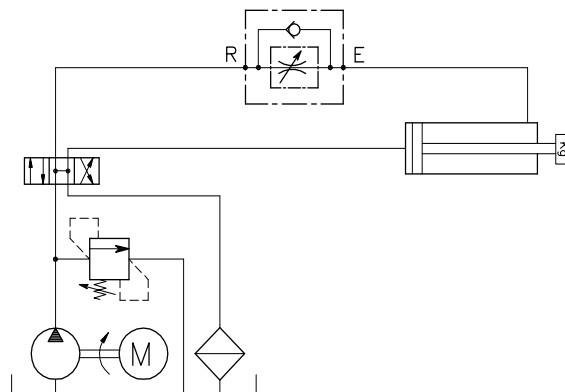

CODICE DI ORDINAZIONE HOW TO ORDER

004 024 0 X 0

Regolazione Adjustment	
X	A chiave - Spanner
Y	Volantino - handknob

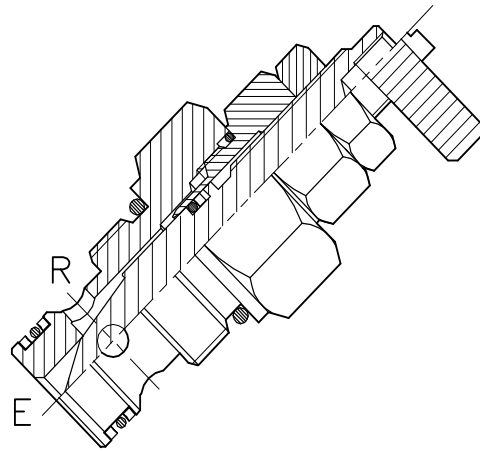
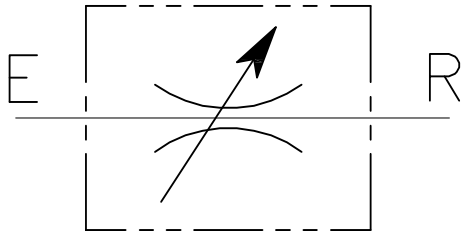

CARATTERISTICHE

Luce nominale	DN 8
Portata min/max	1/45 L/min - 0,26/11,9 GPM
Pressione di lavoro max.	350 bar - 5075 PSI
Temperatura ambiente	-30°C + 50°C
Temperatura olio	-30°C + 80°C
Filtraggio controllato	50 micron
Coppia di serraggio	48-54 Nm
Peso	0,161 kg

PERFORMANCE

Size
Min/max flow-rate
Max peak pressure
Room temperature
Oil temperature
Recommended filtration
Tightening torque
Weight

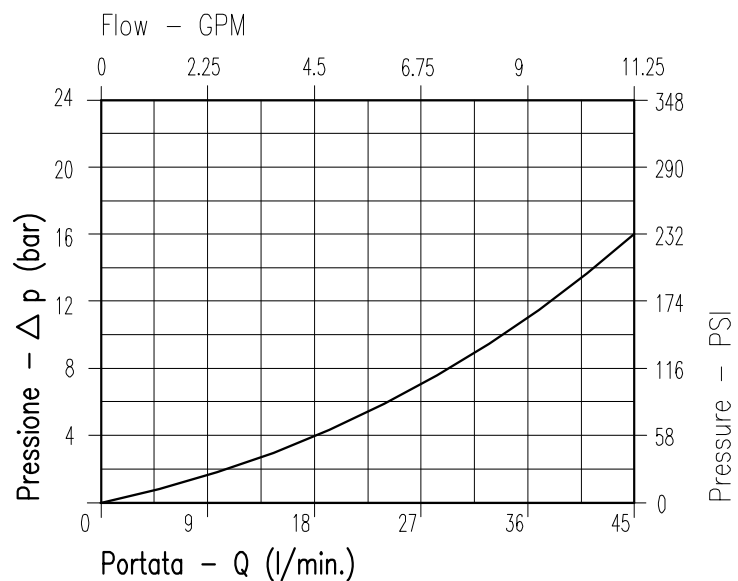

Viscosità olio 46 cSt a 50°C
Oil viscosity 46 cSt at 50°C

VALVOLA REGOLATRICE DI FLUSSO A CARTUCCIA BIDIREZIONALE
CARTRIDGE STYLE FLOW RESTRICTOR VALVE

REGOLAZIONE
ADJUSTMENT →

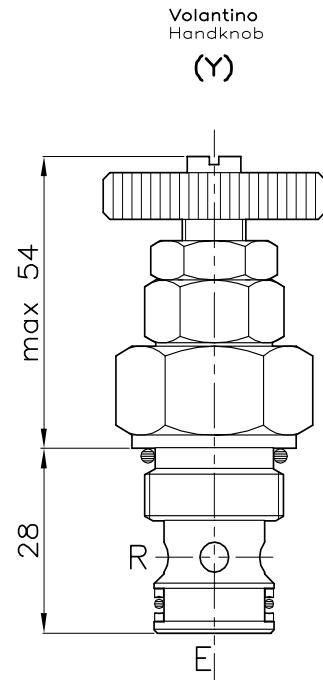
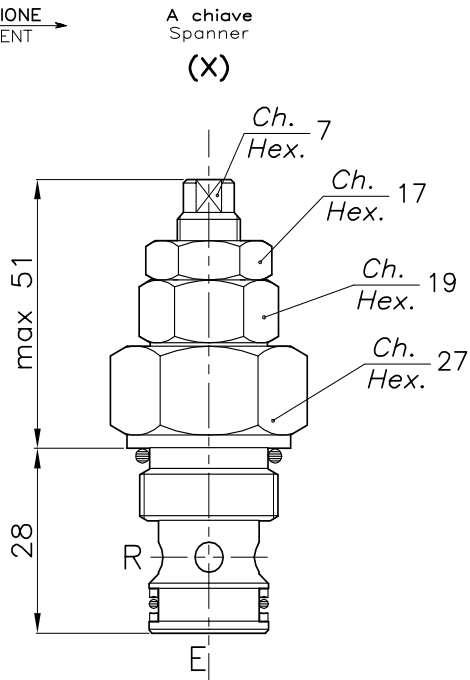

CAVITA' CAVITY CE.014.N

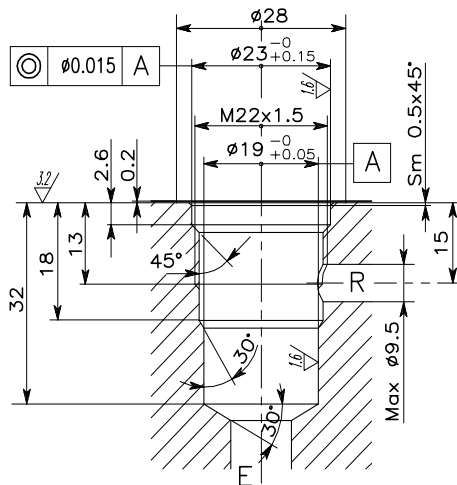

Si raccomanda l'esatta esecuzione della sede
The valve seat should be perfectly tooled

**ESEMPIO TIPICO DI CIRCUITO
TYPICAL CIRCUIT EXAMPLE**

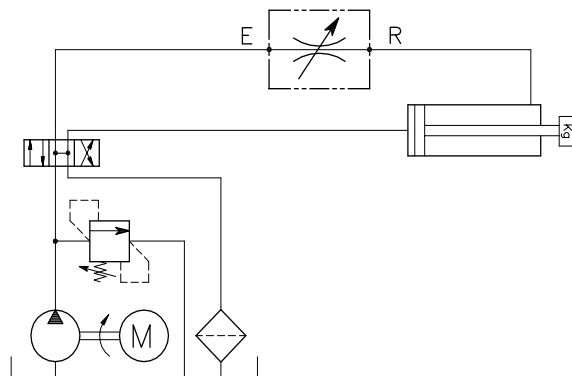

**CODICE DI ORDINAZIONE
HOW TO ORDER**

004 018 0 X 0

Regolazione Adjustment	
X	A chiave - Spanner
Y	Volantino - handknob

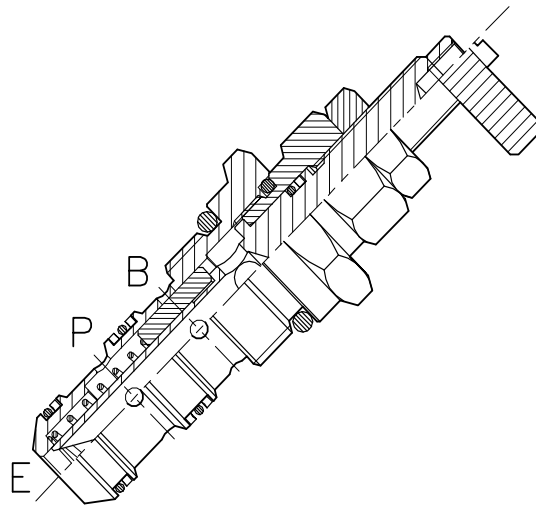
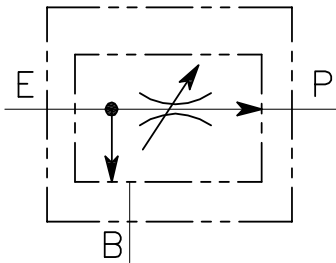

CARATTERISTICHE

Luce nominale	DN 8
Portata min/max QE	1/40 L/min - 0,26/10,6 GPM
Portata max. QP	25 L/min - 6,6 GPM
Pressione di lavoro max.	210 bar - 3045 PSI
Temperatura ambiente	-30°C + 50°C
Temperatura olio	-30°C + 80°C
Filtraggio controllato	50 micron
Copia di serraggio	50-60 Nm
Peso	0,157 kg

PERFORMANCE

Size
QE Min/max flow-rate
QP max. flow-rate
Max peak pressure
Room temperature
Oil temperature
Recommended filtration
Tightening torque
Weight

NOTE:

Flusso compensato da E verso P.
Flusso inverso consentito ma non compensato (funziona in modo strozzato).

Compensated flow from E to P.
Reverse flow allowed but not compensated (throttle operation)

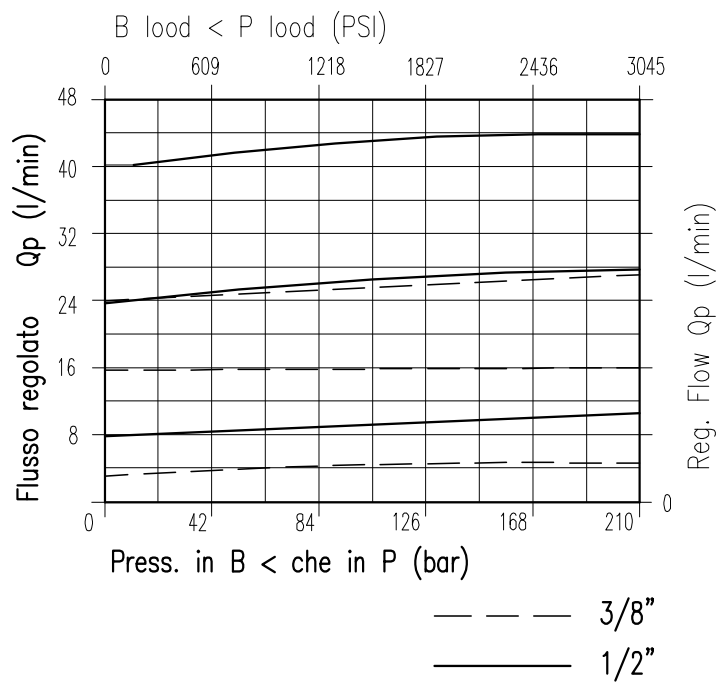

Viscosità olio 46 cSt a 50°C
Oil viscosity 46 cSt at 50°C

REGOLATORE DI FLUSSO PRIORITARIO A CARTUCCIA CON ECCEDENZA IN PRESSIONE
CARTRIDGE STYLE PRIORITY FLOW CONTROL VALVE

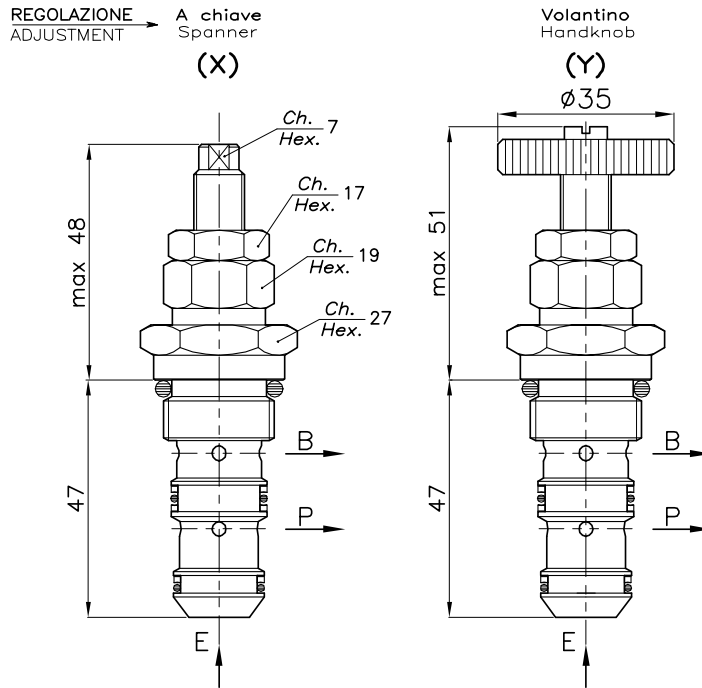

CAVITA' CAVITY CE.017.N

ESEMPIO TIPICO DI CIRCUITO TYPICAL CIRCUIT EXAMPLE

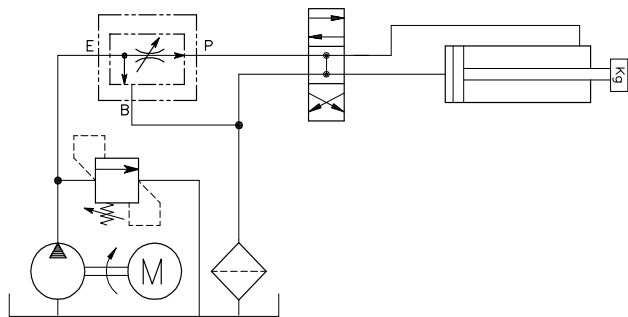
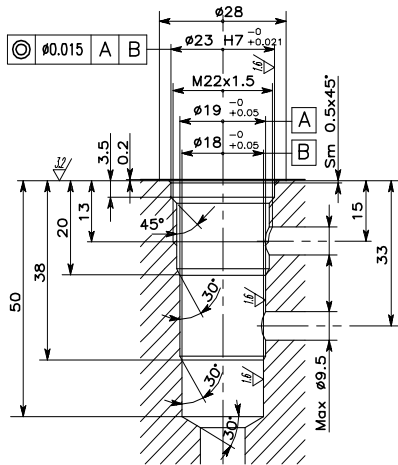

Si raccomanda l'esatta esecuzione della sede
 The valve seat should be perfectly tooled

CODICE DI ORDINAZIONE HOW TO ORDER

004 001 0 X 0

Regolazione Adjustment	
X	A chiave - Spanner
Y	Volantino - handknob

VRF-C-3V-60

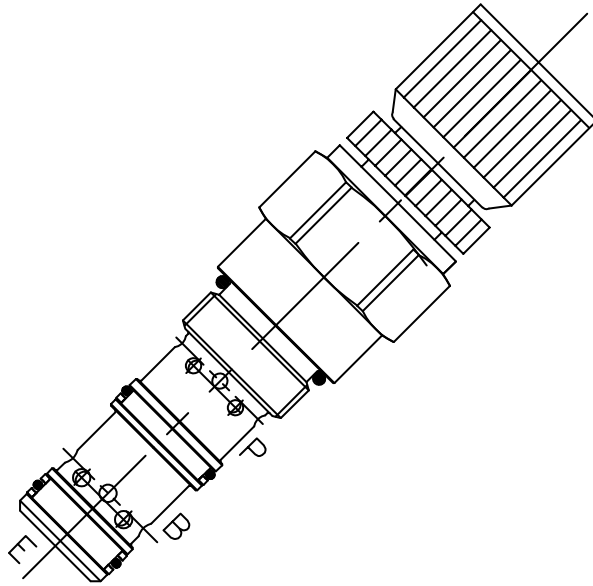
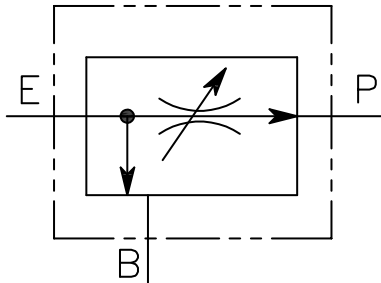

CARATTERISTICHE

Portata min/max in ingresso	0.5/60 L/min - 0.1/16 GPM
Portata min/max regolata	0.5/30 L/min - 0.1/8 GPM
Pressione di lavoro Max.	315 bar 4568 PSI
Temperatura ambiente	-30 + 50°C
Temperatura olio	-30 + 80°C
Filtraggio consigliato	25 micron
Coppia di serraggio	50 ÷ 60 Nn
Peso	0.260 kg

PERFORMANCE

Min/max inlet flow-rate
Min/max regulated flow-rate
Max working pressure
Room temperature
Oil temperature
Recommended filtration
Tightening torque
Weight

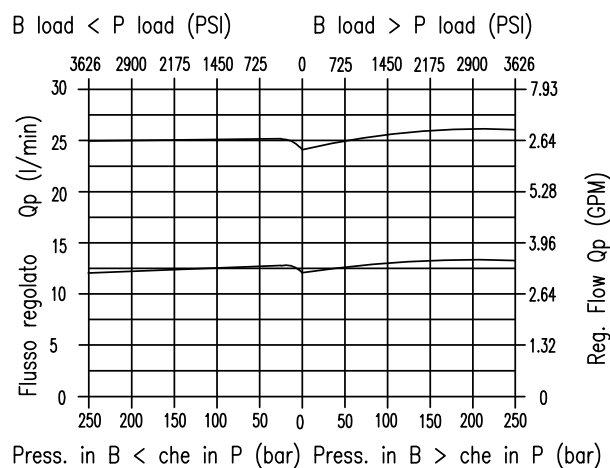

Viscosita' olio 46 cSt a 50° C
Oil viscosity 46 cSt at 50° C

REGOLATORE DI FLUSSO PRIORITARIO A CARTUCCIA CON ECCEDENZA IN PRESSIONE
CARTRIDGE STYLE PRIORITY FLOW CONTROL VALVE

REGOLAZIONE → Pomello graduato
 ADJUSTMENT → Graduated handknob
 (H)

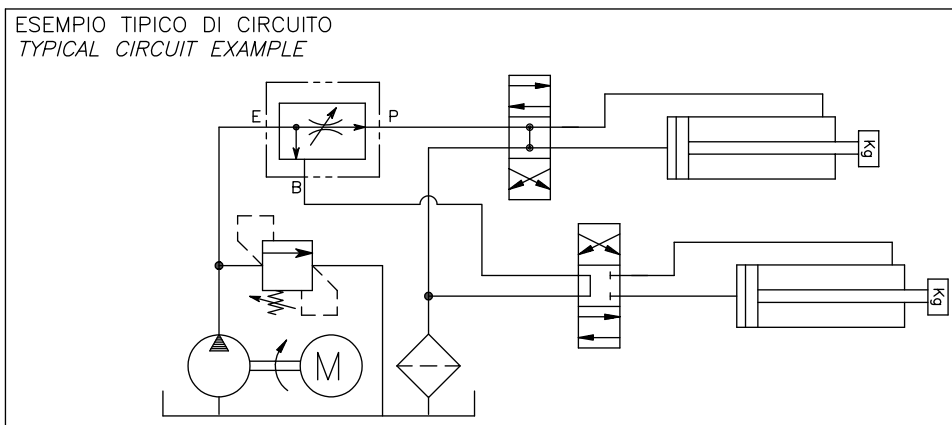
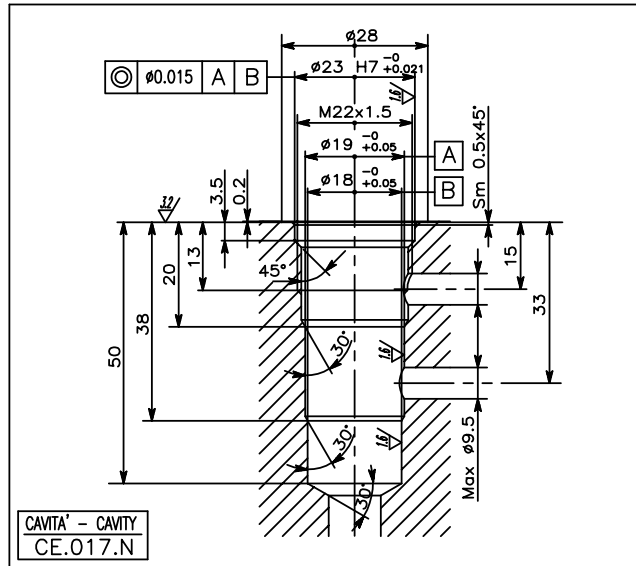
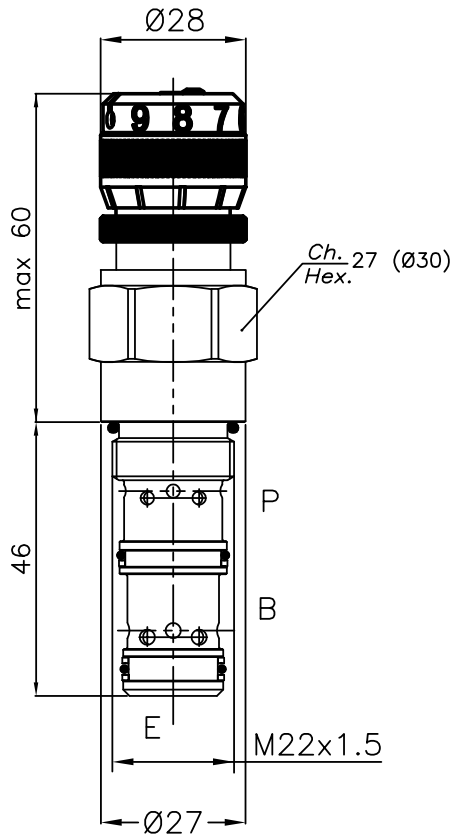

CODICE DI ORDINAZIONE
HOW TO ORDER

004 . 248 . 0 H 0

VRF-C-3V-100-...

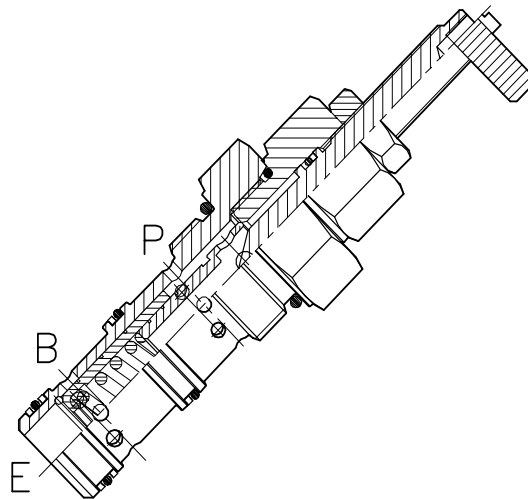
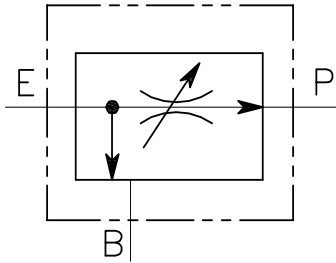

CARATTERISTICHE

Luce nominale	DN 12
Portata min/max	1/100 l/min - 0.26/26.4 GPM
Pressione di lavoro max.	350 bar - 5075 PSI
Temperatura ambiente	-30°C + 50°C
Temperatura olio	-30°C + 80°C
Filtraggio consigliato	50 micron
Coppia di serraggio	80÷90 Nm
Peso	0.313 Kg

PERFORMANCE

Rated size
Min/max flow-rate
Max working pressure
Room temperature
Oil temperature
Recommended filtration
Tightening torque
Weight

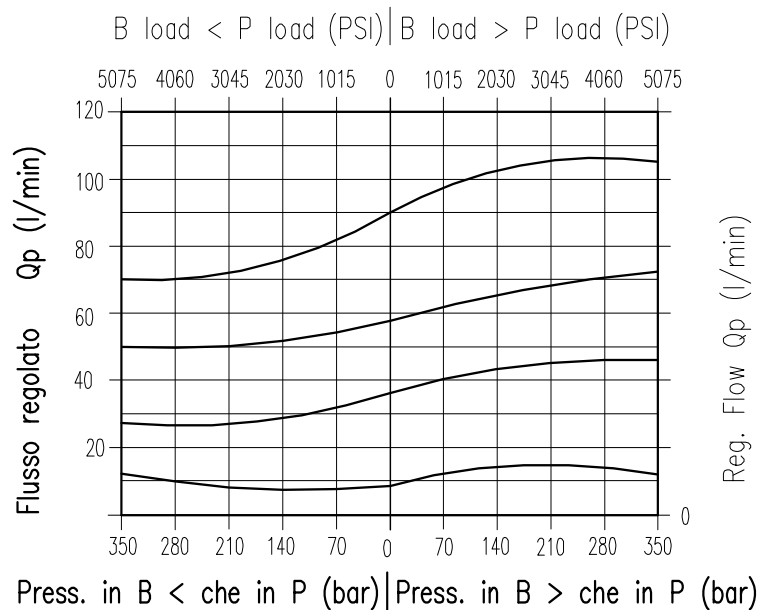

Viscosità olio 46 cSt a 50°C
Oil viscosity 46 cSt at 50°C

REGOLATORE DI FLUSSO PRIORITARIO A CARTUCCIA CON ECCEDENZIA IN PRESSIONE
CARTRIDGE STYLE PRIORITY FLOW CONTROL VALVE

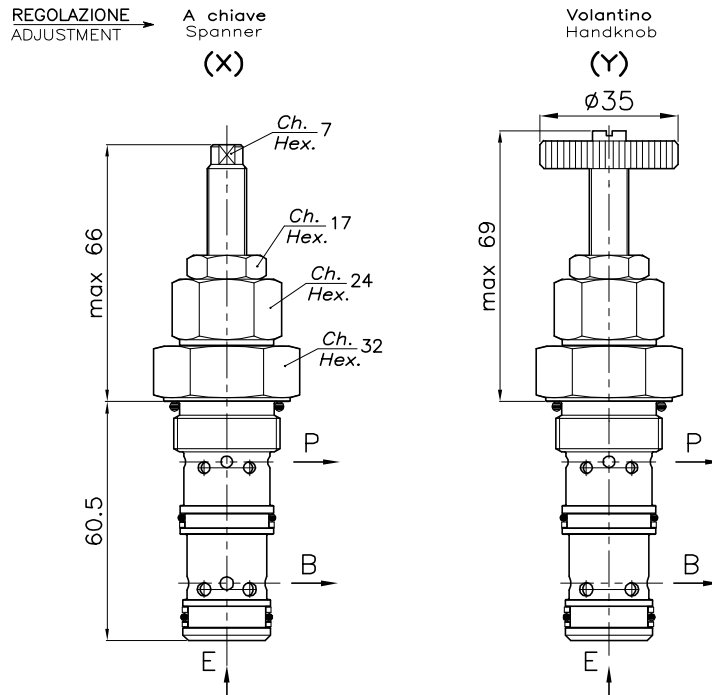

CAVITA' CAVITY CE.025.N

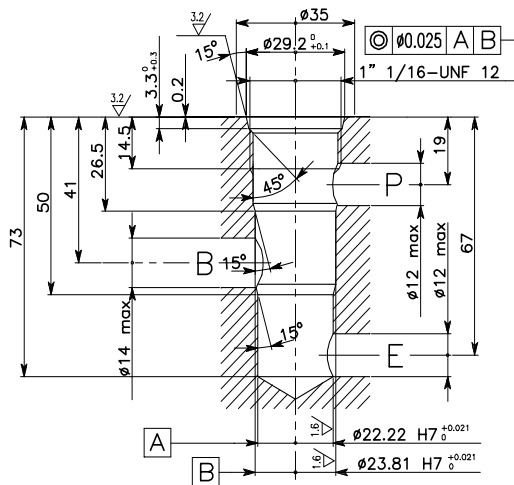

Si raccomanda l'esatta esecuzione della sede
 The valve seat should be perfectly tooled

ESEMPIO TIPICO DI CIRCUITO TYPICAL CIRCUIT EXAMPLE

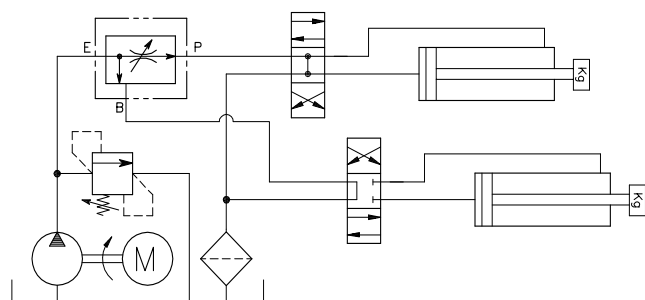

CODICE DI ORDINAZIONE HOW TO ORDER

004 208 0 X 0

Regolazione Adjustment	
X	A chiave - Spanner
Y	Volantino - handknob

VRF-CN-3V-C-...-L-...

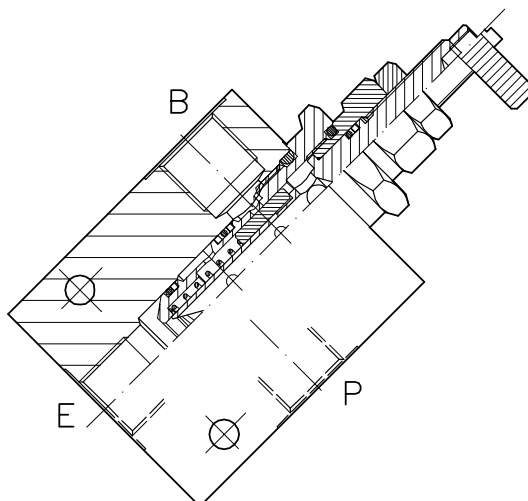
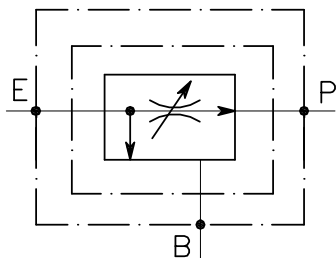

CARATTERISTICHE

Luce nominale	DN 6
Portata min/max	1/45 l/min - 0.26/11.9 GPM
Pressione di lavoro max.	210 bar - 3045 PSI
Temperatura ambiente	-30°C + 50°C
Temperatura olio	-30°C + 80°C
Filtraggio consigliato	50 micron
Peso	0.426 Kg. 3/8" GAS
Peso	0.526 Kg. 1/2" GAS

PERFORMANCE

Rated size
Min/max flow-rate
Max working pressure
Room temperature
Oil temperature
Recommended filtration
Weight
Weight

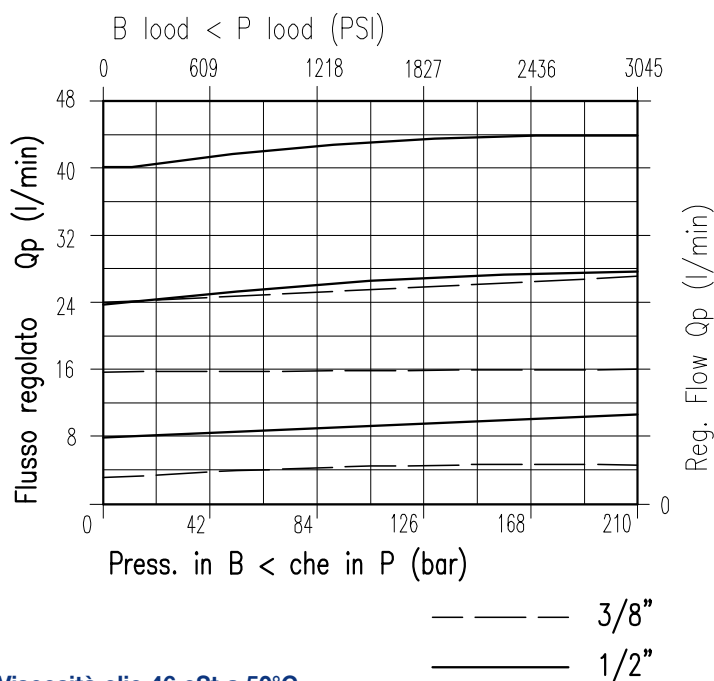

Viscosità olio 46 cSt a 50°C
Oil viscosity 46 cSt at 50°C

REGOLATORE DI FLUSSO PRIORITARIO A CARTUCCIA CON ECCEDENZA IN SCARICO E COLLETTORE
CARTRIDGE STYLE FLOW CONTROL VALVE WITH IN LINE BODY

REGOLAZIONE
ADJUSTMENT →

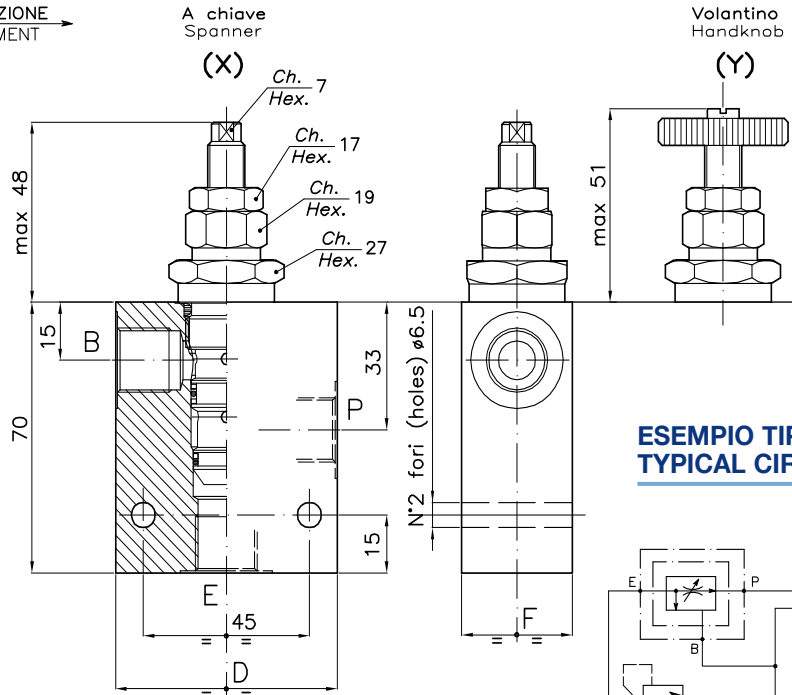

ESEMPIO TIPICO DI CIRCUITO
TYPICAL CIRCUIT EXAMPLE

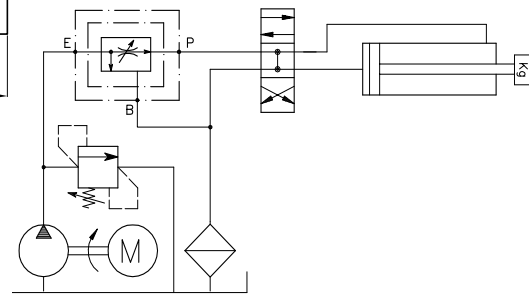

DIMENSIONI
DIMENSIONS

NUMERO VALVOLA VALVE NUMBER	D	F	Attacchi Port size E-P-B GAS (BSPP)	Portata max Max flow-rate l/min - GPM
016	60	30	3/8"	30-7.9
017	70	35	1/2"	45-11.9

CODICE DI ORDINAZIONE
HOW TO ORDER

004 016 0 X 0

Numero valvola / Valve number

016

017

Regolazione
Adjustment

X | A chiave - Spanner

Y | Volantino - handknob

VRF-C-3V-60- ...

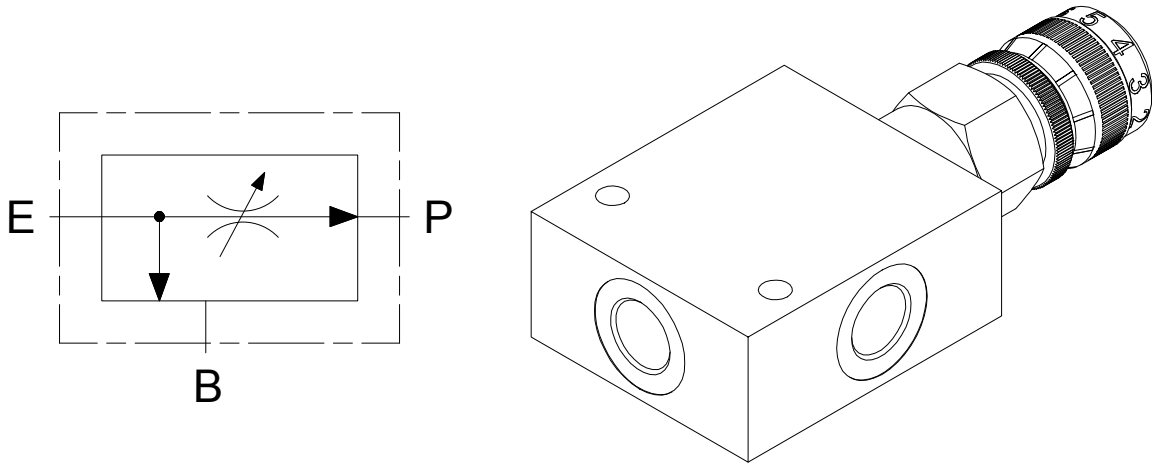

CARATTERISTICHE

Portata min/max in ingresso	0.5/60 L/min - 0.1/16 GPM
Portata min/max regolata	0.5/30 L/min - 0.1/8 GPM
Pressione di lavoro Max.	315 bar 4568 PSI
Temperatura ambiente	-30 + 50°C
Temperatura olio	-30 + 80°C
Filtraggio consigliato	25 micron
Collettori in alluminio	

PERFORMANCE

Min/max inlet flow-rate
Min/max regulated flow-rate
Max working pressure
Room temperature
Oil temperature
Recommended filtration
Aluminium body

ESEMPIO TIPICO DI CIRCUITO
TYPICAL CIRCUIT EXAMPLE

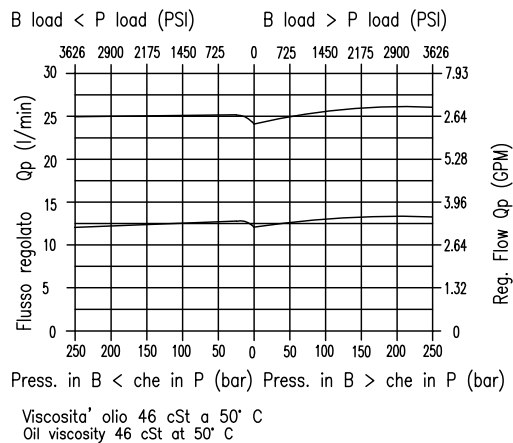
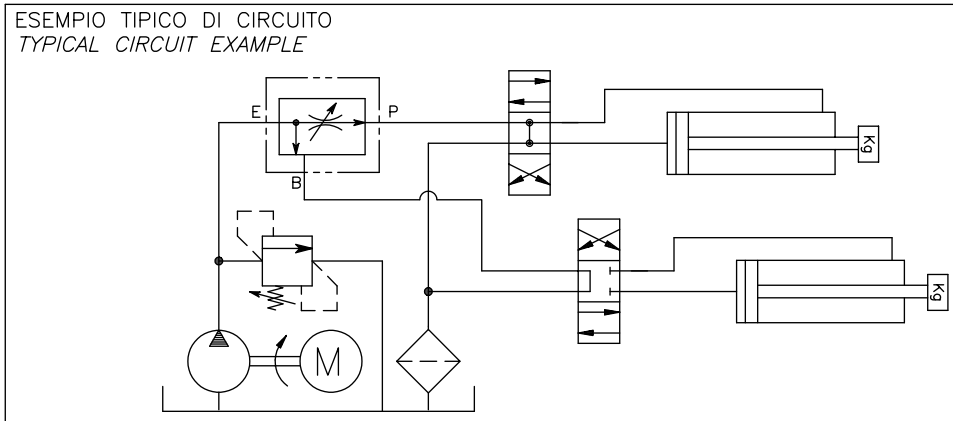

**REGOLATORE DI FLUSSO PRIORITARIO CON ECCEDEZZA IN PRESSIONE CON COLLETTORE
CARTRIDGE STYLE PRIORITY FLOW CONTROL VALVE WITH BODY.**

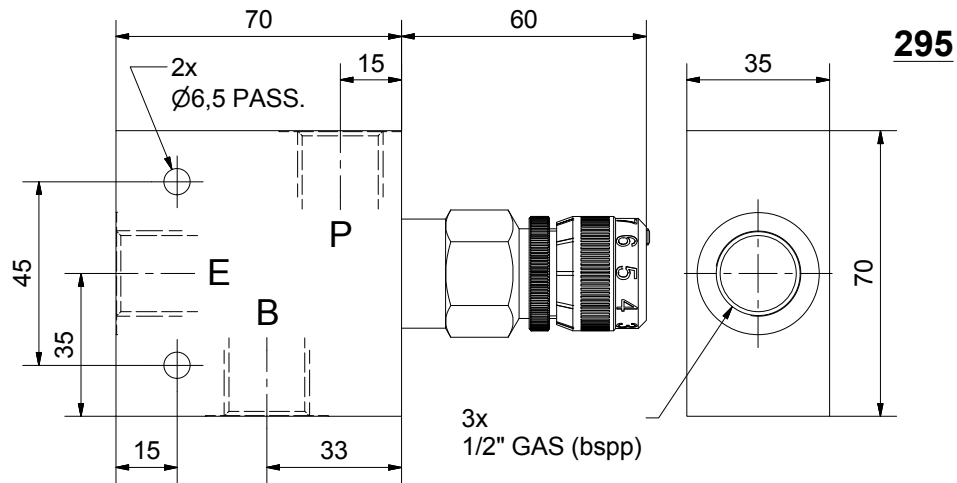
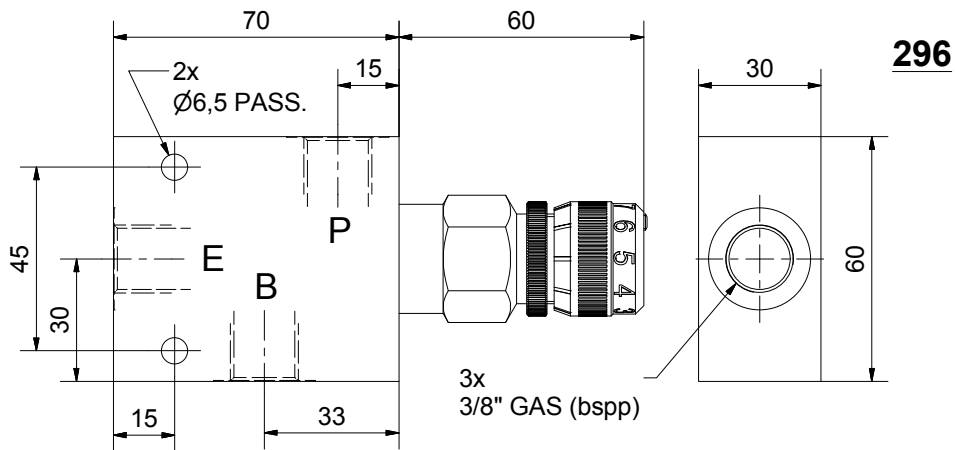
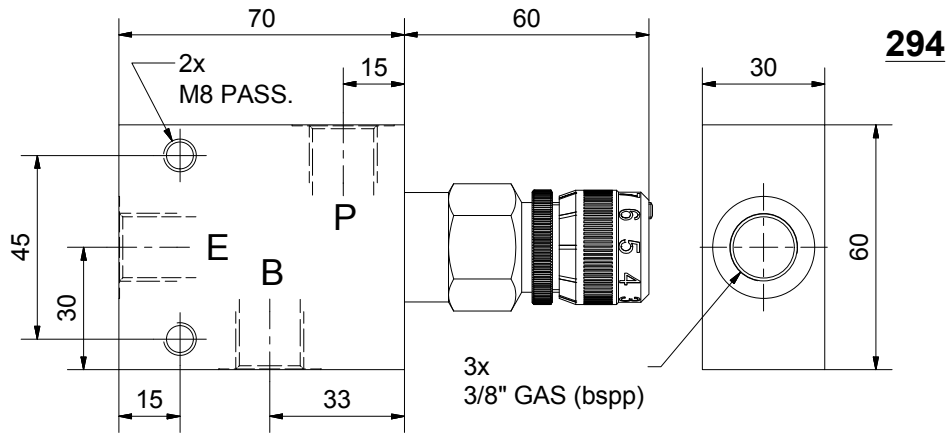

**CODICE DI ORDINAZIONE
HOW TO ORDER**

004	.	294	.	0	H	0
004	.	296	.	0	H	0
004	.	295	.	0	H	0

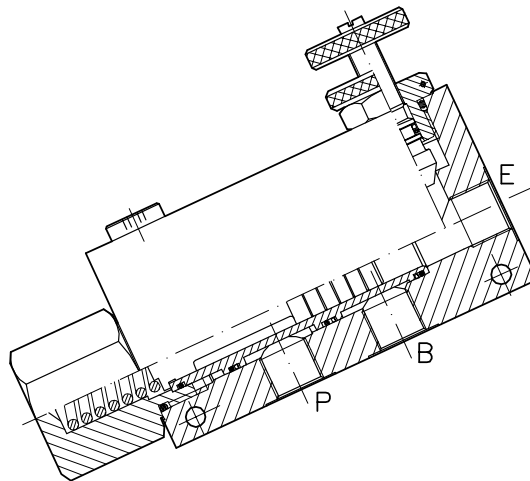
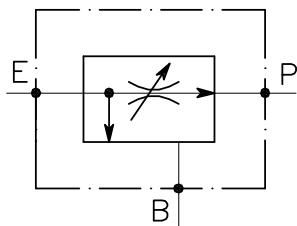

CARATTERISTICHE

Luce nominale min/max	DN 6/11
Portata min/max	1/150 l/min - 0.26/39.6 GPM
Pressione di lavoro max.	210 bar - 3045 PSI
Temperatura ambiente	-30°C + 50°C
Temperatura olio	-30°C + 80°C
Filtraggio consigliato	50 micron
Peso	1.194 Kg, 3/8" GAS
Peso	1.171 Kg, 1/2" GAS
Peso (*)	2.144 Kg, 3/4" GAS

PERFORMANCE

Min/max rated size
Min/max flow-rate
Max working pressure
Room temperature
Oil temperature
Recommended filtration
Weight
Weight
Weight

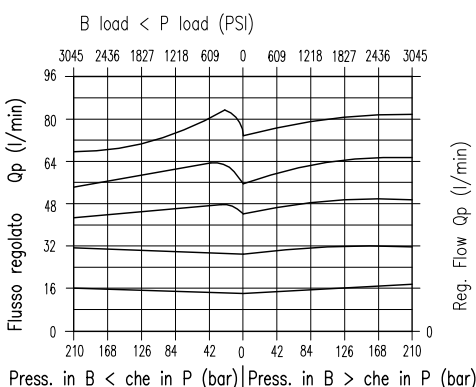
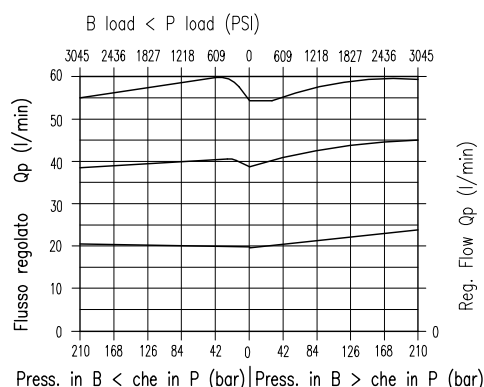
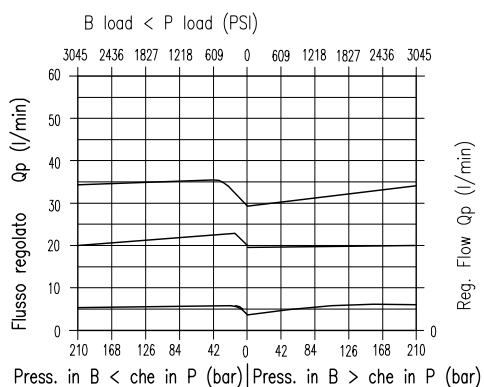

(*) Per un corretto funzionamento della valvola, nel caso in cui la porta "B" sia in scarico, è necessario avere una pressione in "B" di 6 - 8 bar.
To ensure the proper functioning of the valve, in case the port "B" is in discharge, it is necessary to have a pressure in "B" of 6 - 8 bar.

Viscosità olio 46 cSt a 50°C / Oil viscosity 46 cSt at 50°C

REGOLATORE DI FLUSSO PRIORITARIO CON ECCEDENZIA IN PRESSIONE
PRIORITY FLOW CONTROL COMBINATION STYLE

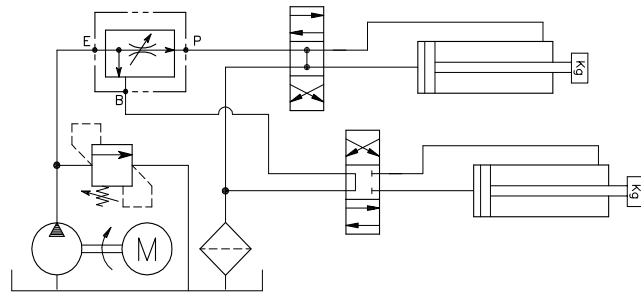
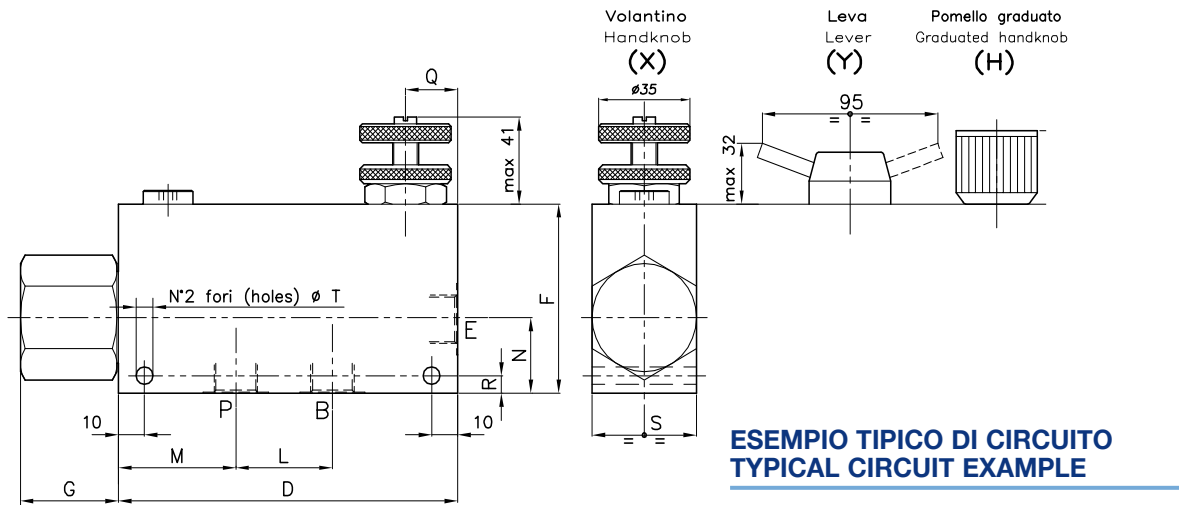

DIMENSIONI
DIMENSIONS

NUMERO VALVOLA VALVE NUMBER	D	F	G	L	M	N	Q	R	S	T	Attacchi Port size E-P-B GAS (BSPP)	Luce nominale Rated size DN	QP l/min - GPM	QE l/min - GPM
003	130	70	38	37	45	28	20	6.5	40	6.5	3/8"	6	30-7.9	55-14.5
005	130	70	38	37	45	28	20	6.5	40	6.5	1/2"	8	55-14.5	90-23.8
007	155	90	35	44	54	35	25	7.5	50	8.5	3/4"	11	90-23.8	150-39.6

QE = Portata max in entrata "E" - l/min
QE = Max admitted inlet flow "E" - l/min

QP = Portata max in uscita prioritario "P" - l/min
QP = Max delivery in priority "P" - l/min

CODICE DI ORDINAZIONE
HOW TO ORDER

004

003

0

X

0

Numero valvola / Valve number

003

005

007

Regolazione
Adjustment

X	Volantino - Handknob
Y	Leva - Lever
H	Pomello graduato - Graduated handknob
Z	Volantino in alluminio - Aluminium handknob

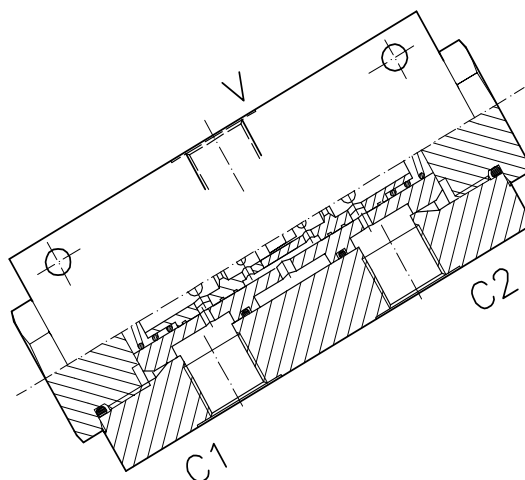
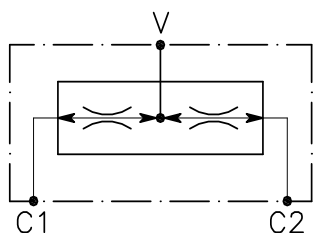

CARATTERISTICHE

Rapporto di flusso	50%
Portata min/max	Vedi pag. 44
Pressione di lavoro max.	210 bar - 3075 PSI
Temperatura ambiente	-30°C + 50°C
Temperatura olio	-30°C + 80°C
Filtraggio consigliato	50 micron
Peso	0.869 Kg. 3/8" GAS
Peso	0.850 Kg. 1/2" GAS

PERFORMANCE

Flow division ratio
Min/max flow-rate
Max working pressure
Room temperature
Oil temperature
Recommended filtration
Weight
Weight

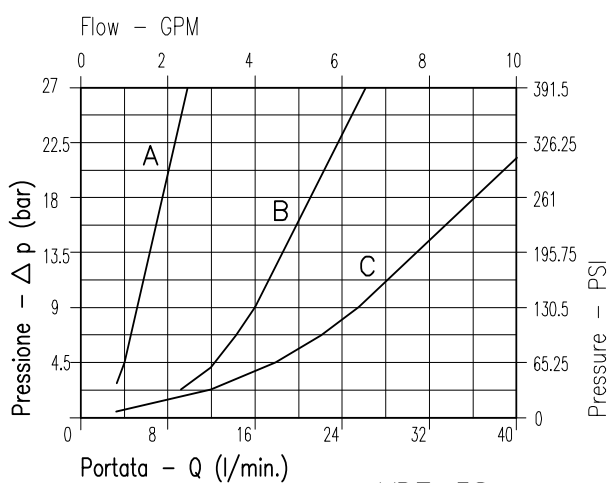

VDF-38
VDF-12

Viscosità olio 46 cSt a 50°C
Oil viscosity 46 cSt at 50°C

VALVOLA DIVISORE/RIUNIFICATORE DI FLUSSO
FLOW DIVIDER/COMBINER

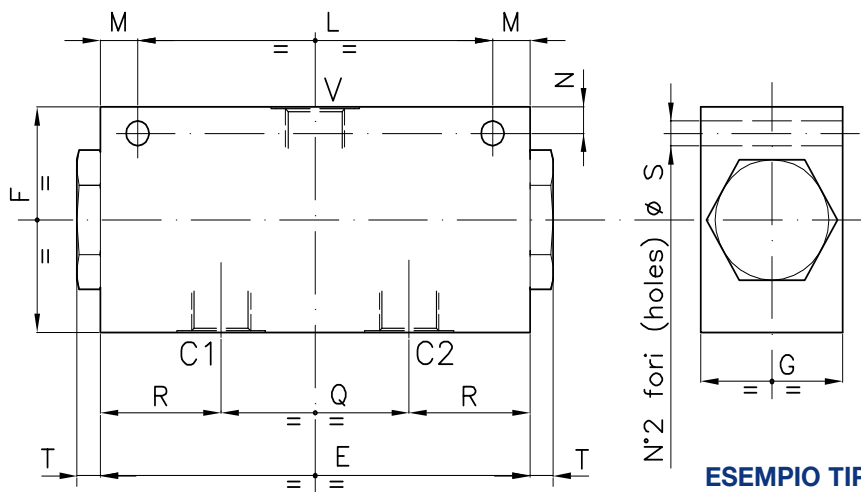

ESEMPIO TIPICO DI CIRCUITO
TYPICAL CIRCUIT EXAMPLE

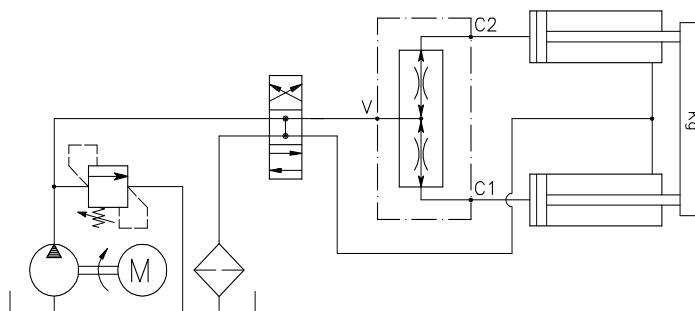

DIMENSIONI
DIMENSIONS

NUMERO VALVOLA VALVE NUMBER	E	F	G	L	M	N	Q	R	S	T	Attacchi Port size V GAS (BSPP)	Attacchi Port size C1-C2 GAS (BSPP)
008	121	60	40	100	10.5	7	53	34	6.5	7	3/8"	3/8"
009	121	60	40	100	10.5	7	53	34	6.5	7	1/2"	3/8"

CODICE DI ORDINAZIONE
HOW TO ORDER

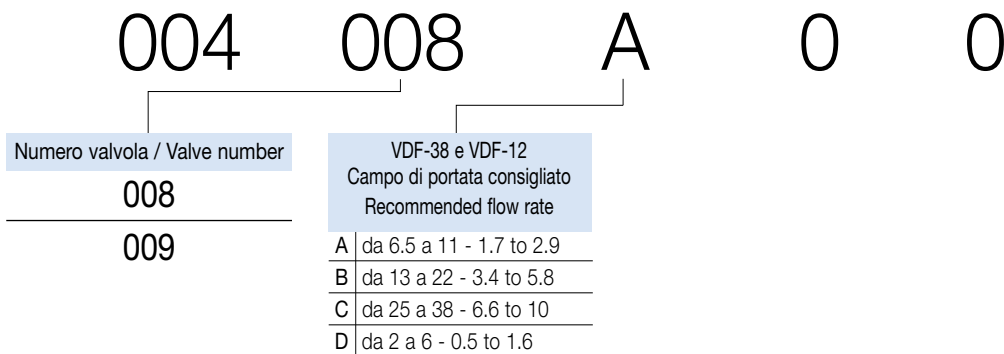

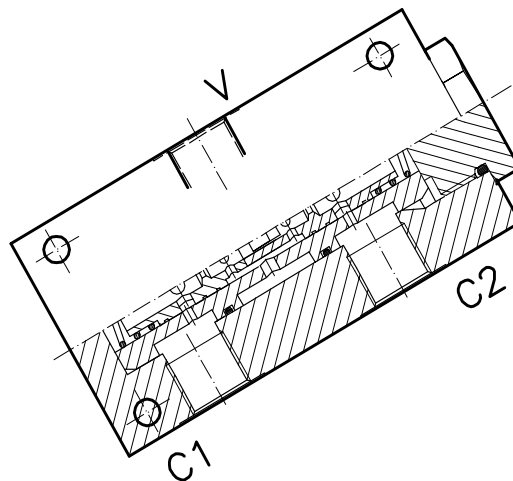
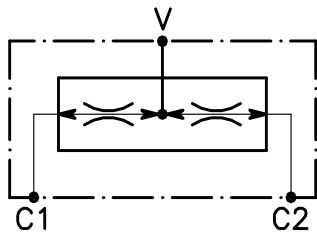

CARATTERISTICHE

Rapporto di flusso	50%
Portata min/max	Vedi pag. 02
Pressione di lavoro max.	210 bar - 3075 PSI
Temperatura ambiente	-30°C + 50°C
Temperatura olio	-30°C + 80°C
Filtraggio consigliato	50 micron

PERFORMANCE

Flow division ratio
Min/max flow-rate
Max working pressure
Room temperature
Oil temperature
Recommended filtration

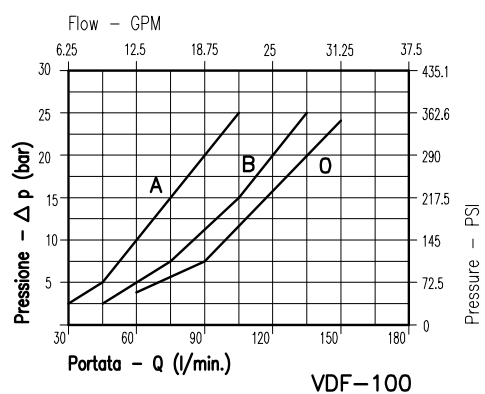
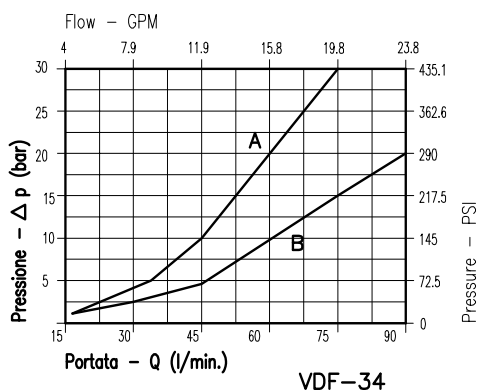

Viscosità olio 46 cSt a 50°C / Oil viscosity 46 cSt at 50°C

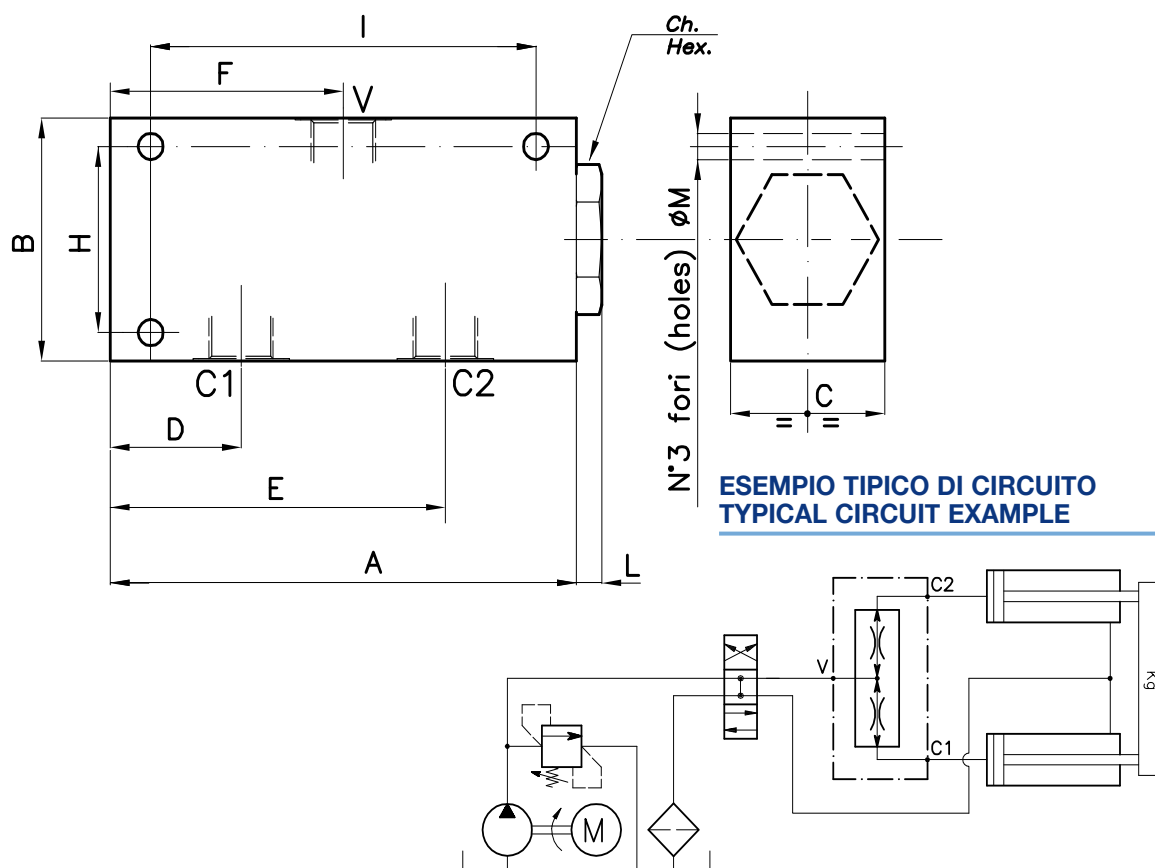

**DIMENSIONI
DIMENSIONS**

NUMERO VALVOLA VALVE NUMBER	A	B	C	D	E	F	H	I	L	M	CH hex	Attacchi Port size V GAS (BSPP)	Attacchi Port size C1 - C2 GAS (BSPP)	Sigla Title
056	120	80	40	42	90	66	60	102	9.5	6.5	32	3/4"	1/2"	VDF-34
059	120	100	50	37	95	66	82	102	12	8.5	38	1"	3/4"	VDF-100

**CODICE DI ORDINAZIONE
HOW TO ORDER**

004 056 A 0 0

Numero valvola Valve number	VDF - 34 Campo di portata consigliato Recommended inlet flow rate l/min - GPM	VDF - 100 Campo di portata consigliato Recommended inlet flow rate l/min - GPM
056	A da 15 a 60 - 4 to 15.8	A da 30 a 100 - 7.9 to 26
059	B da 15 a 90 - 4 to 23.8	B da 45 a 128 - 11.9 to 34
		O da 60 a 167 - 14.8 to 44

Sono valvole regolatrici di flusso ad inserto filettato a 2 vie compensate alla pressione ed a regolazione fissa. Sono disponibili in tre grandezze costruttive tutte molto compatte, di piccole dimensioni e di facile montaggio. La portata viene pre-selezionata tramite il foro calibrato presente sul pistoncino compensatore e mantenuta costante (da B verso A) indipendente dalla pressione e dalla viscosità dell'olio. Nella direzione opposta il flusso (non compensato) attraversa la valvola strozzata creando una caduta di pressione dovuta e corrispondente al foro calibrato scelto.

They are flow control valves, two ways, pressure compensated and with fixed orifice. Flow setting is preadjusted through the calibrated orifice drilled on the compensator piston and is kept constant from B to A regardless of the Δp between port B to A. On the opposite direction the flow is restricted (not pressure compensated) according to the orifice size.

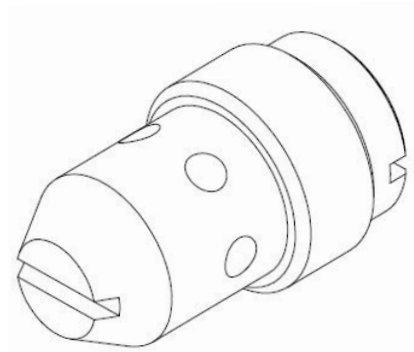

CARATTERISTICHE

Grandezza	1/4"- 3/8"-1/2"
Portata min/max	Vedi tabella - See table
Pressione max. di picco	250 bar
Pressione di lavoro max.	210 bar
Temperatura ambiente	-30°C + 50°C
Temperatura olio	-30°C + 80°C
Filtraggio consigliato	30
Peso	Vedi tabella - See table

PERFORMANCE

Rated size
Min/max flow-rate
Max peak pressure
Max working pressure
Room temperature
Oil temperature
Recommended filtration
Weight

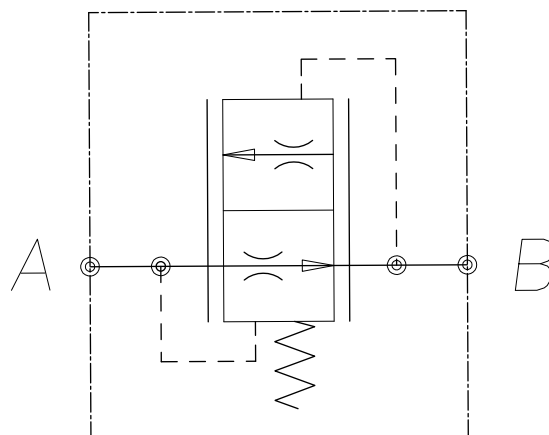

VALVOLE STROZZATRICI COMPENSATE ALLA PRESSIONE
PRESSURE COMPENSATED FLOW RESTRICTORS

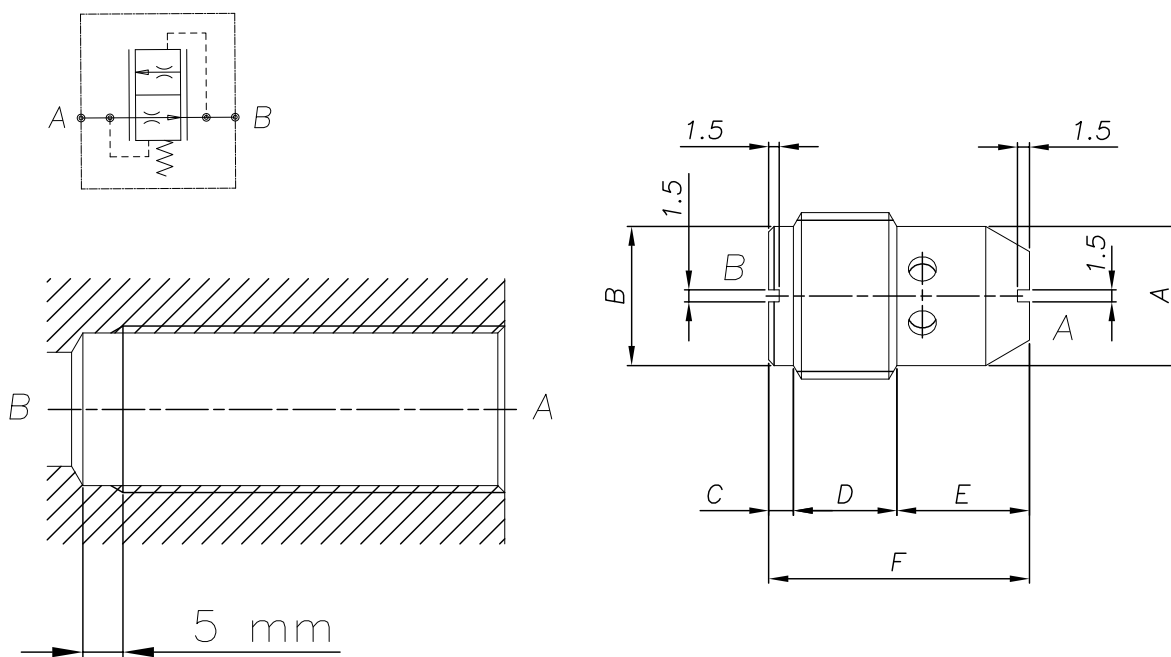

Attacchi Ports	Portata Max Max Flow	A	B	C	D	E	F	Peso Weight (KG)
1/4" GAS	15 (L/min)	10	11	3	9	13.5	25.5	0.013
3/8" GAS	28 (L/min)	14	14.5	2	11	15	28	0.027
1/2" GAS	45 (L/min)	17.5	17.5	2	13.5	19.5	35	0.054

INSERTO FILETTATO INSERT THREAD	SIGLA VALVOLE VALVE CODE	NUMERO VALVOLA VALVE NUMBER
1/4" GAS	VSC-14-*	256
3/8" GAS	VSC-38-*	257
1/2" GAS	VSC-12-*	258

CODICE DI ORDINAZIONE
HOW TO ORDER

004 258 A 0 0

FILETTATURA VALVE SIZE	PORTATA CONTROLLATA L/min FLOW SET RANGE L/min																		
	A	B	C	D	E	F	H	J	K	L	M	N	P	R	S	T	X	J	Z
1/4" GAS	0.6	0.8	1	1.2	1.4	1.6	1.8	2	3	4	5	6	7	8	9	10	11	12	15
3/8" GAS	3	4	5	6	7	8	9	10	11	14	16	18	20	23	28				
1/2" GAS	12	16	20	25	30	35	40	43											

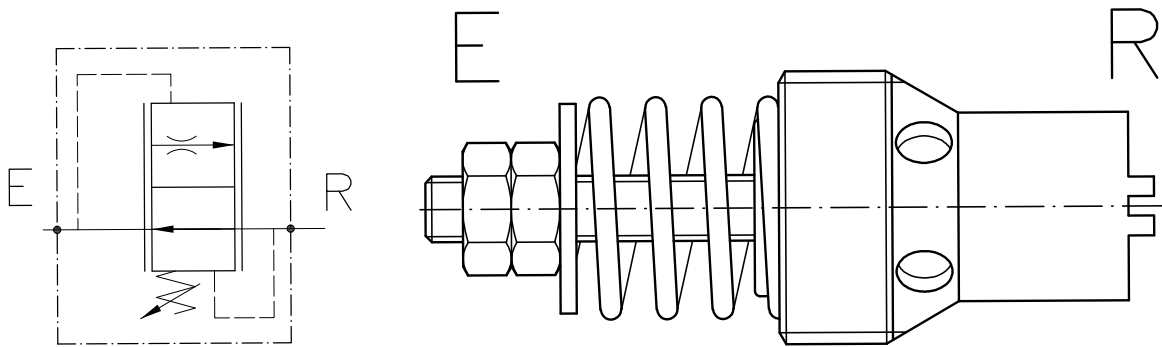

CARATTERISTICHE

Grandezza	1/4" - 3/8" - 1/2" - 3/4" - 1" - 1 1/4" - 1 1/2"
Portata min/max	Vedi tabella - See table
Pressione max. di picco	1/4" 3/8" 1/2" 3/4" - 300 bar - 1" 1 1/4" 1 1/2" 250 bar
Temperatura ambiente	-30°C + 50°C
Temperatura olio	-30°C + 80°C
Filtraggio consigliato	30
Peso	0.013/0.270

PERFORMANCE

Rated size
Min/max flow-rate
Max peak pressure
Room temperature
Oil temperature
Recommended filtration
Weight

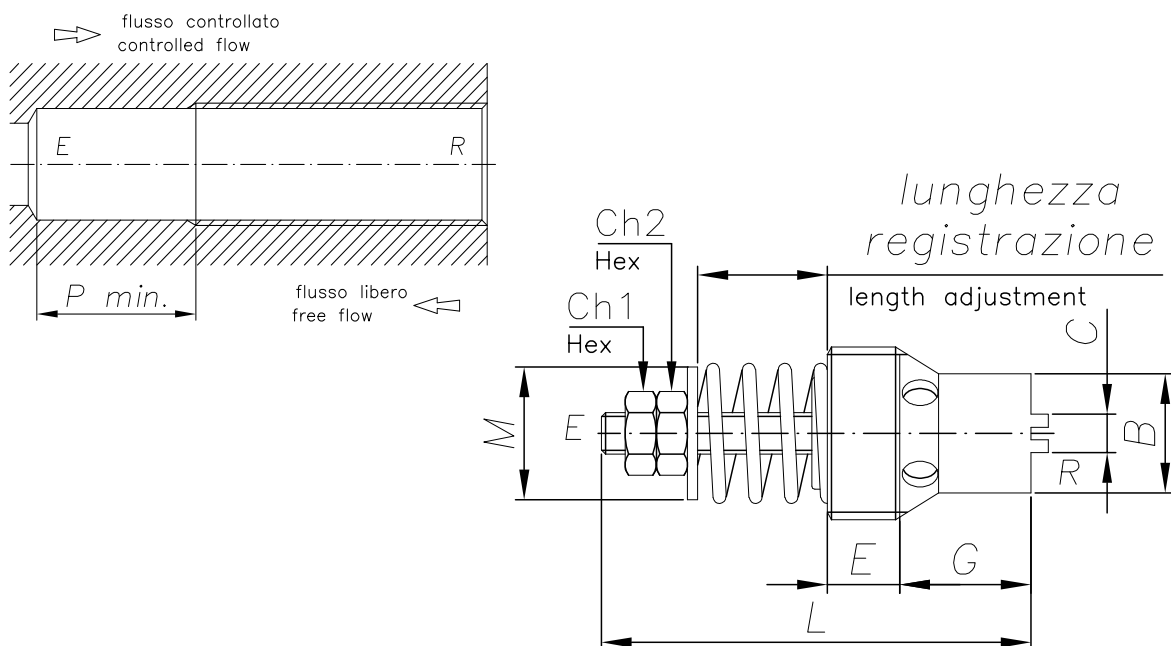

VALVOLA CONTROLLO PORTATA A INSERTO
LOWERING CONTROL COMPENSATED VALVE

Sigla valvola Valve sign	Codice ordinazione Ordering code	B	C	E	G	L	M	CH1	CH2	Attacchi Ports GAS	Portata MAX MAX flow L/min - GPM	Peso Weight Kg
VB-14	001.021.*00	10	4	6.5	13.5	39	10	5.5	5.5	1/4"	15- 4	0.013
VB-38	001.031.*00	11.5	6	7	15	45	14	6	7	3/8"	35- 9.2	0.024
VB-12	001.032.*00	16	6	7	16.5	51	18	6	7	1/2"	65- 17.2	0.037
VB-34	001.033.*00	20	8	9.5	21.5	62	23	6	7	3/4"	150- 39.6	0.070
VB-100	001.034.*00	26	14	15	25	82	28.5	8	8	1"	250- 66	0.150
VB-114	001.035.*00	33	8	20.5	31,5	95	35	10	10	1 1/4"	300- 105.7	0.270

Grandezza Inserto Valve size	Portata controllata / Flow range L/min					
	A	B	C	D	E	F
1/4" GAS	1÷1.6	1.5÷2.5	2.4÷4	3.9÷6.3	6.2÷10	9,5÷15
3/8" GAS	2.5÷4	3.9÷6.3	6.1÷10	9.8÷16	15.8÷25	24.5÷35
1/2" GAS	16÷21	20.5÷25	27.5÷37	36.5÷50	48÷65	
3/4" GAS	37÷50	48÷65	63÷90	88÷120	115÷150	
1" GAS	80÷100	100÷130	128÷162	160÷200	195÷250	
1-1/4" GAS	160÷210	205÷250	245÷280	270÷340	330÷400	

001 035 F 0 0

SOLO VALVOLA
ONLY VALVE

SIGLA VALVOLA VALVE CODE	Codice Ordinazione Ordering Code	A	Ch	Attacchi Port size GAS (BSPP)	Peso Weight KG
VBC-14-FF	001.016.*00	66	19	1/4"	0.11
VBC-38-FF	001.041.*00	70	22	3/8"	0.12
VBC-12-FF	001.042.*00	80	27	1/2"	0.20
VBC-34-FF	001.043.*00	99	32	3/4"	0.29
VBC-100-FF	001.044.*00	135	41	1"	0.67
VBC-114-FF	001.045.*00	154	50	1 1/4"	1.04

VALVOLA CON CORPO
VALVE WITH BODY

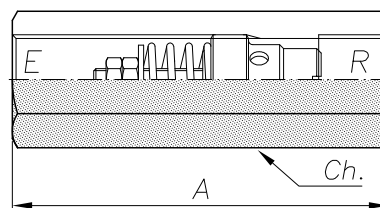

FEMMINA - FEMMINA
FEMALE - FEMALE

SIGLA VALVOLA VALVE CODE	Codice Ordinazione Ordering Code	A	B	C	Ch	Attacchi Port size GAS (BSPP)	Peso Weight KG
VBC-14-MF	001.017.*00	78	66	12	19	1/4"	0.11
VBC-38-MF	001.036.*00	82	70	12	22	3/8"	0.14
VBC-12-MF	001.037.*00	100	85	15	27	1/2"	0.24
VBC-34-MF	001.038.*00	113	96	17	32	3/4"	0.34
VBC-100-MF	001.039.*00	135	110	25	41	1"	0.75
VBC-114-MF	001.040.*00	155	125	30	50	1 1/4"	1.09

MASCHIO - FEMMINA
MALE - FEMALE

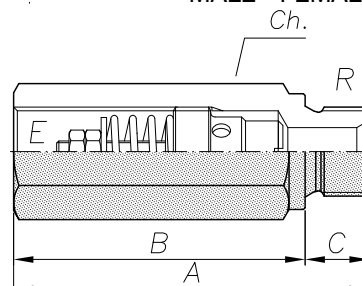

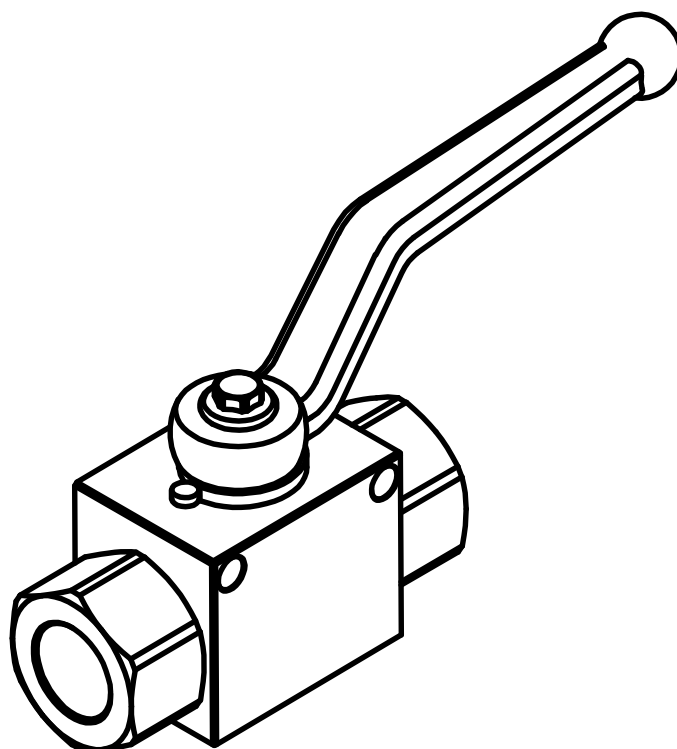

CARATTERISTICHE

Grandezza	1/4"- 3/8"- 1/2"- 3/4"- 1"
Portata min/max	Vedi tabella - See table
Pressione max. di picco	Vedi tabella - See table
Temperatura ambiente	-30°C + 50°C
Temperatura olio	-30°C + 80°C
Filtraggio consigliato	30 micron
Peso	Vedi tabella - See table

PERFORMANCE

Rated size
Min/max flow-rate
Max peak pressure
Room temperature
Oil temperature
Recommended filtration
Weight

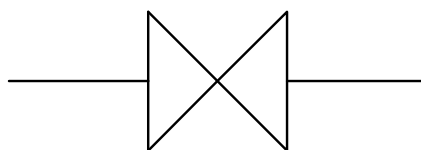

VALVOLE A SFERA 2 VIE ALTA PRESSIONE
HIGH PRESSURE 2-WAY BALL VALVES

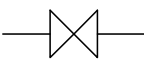
VALVOLE A SFERA 2 VIE ALTA PRESSIONE HIGH PRESSURE 2-WAY BALL VALVES			
Funzione Function	Codice Ordinazione (con fori fissaggio) Ordering Code (with fixing holes)	Attacchi Port Size	Descrizione Description
	003.440.F00 003.441.F00 003.442.F00 003.443.F00 003.444.F00	1/4" GAS 3/8" GAS 1/2" GAS 3/4" GAS 1" GAS	RSAP2-V01 RSAP2-V02 RSAP2-V03 RSAP2-V04 RSAP2-V05

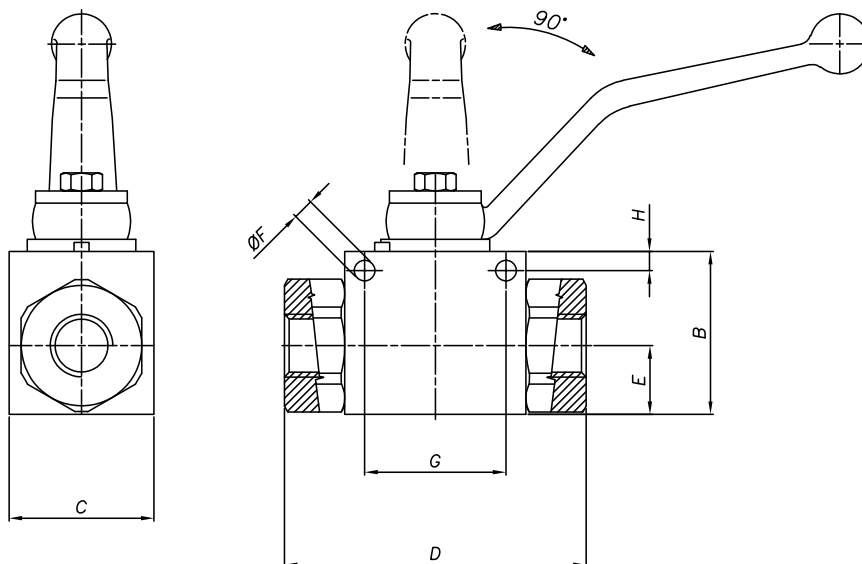

Attacchi Ports	B	C	D	E	ØF	G	H	Portata max Max flow	Pressione Max Pressure	Peso Weight
GAS	mm							l/min	bar	kg
1/4"GAS	35	26	69	14	4.5	32	4.8	15	500	0.4
3/8"GAS	40	32	72	16	5.3	32	5.8	30	500	0.5
1/2"GAS	45	35	83	18	6.5	39	6	60	500	0.7
3/4"GAS	58	50	93	23	6.5	49	6	80	315	1.5
1"GAS	65	57	115	28	8.5	51	7	125	315	2.1

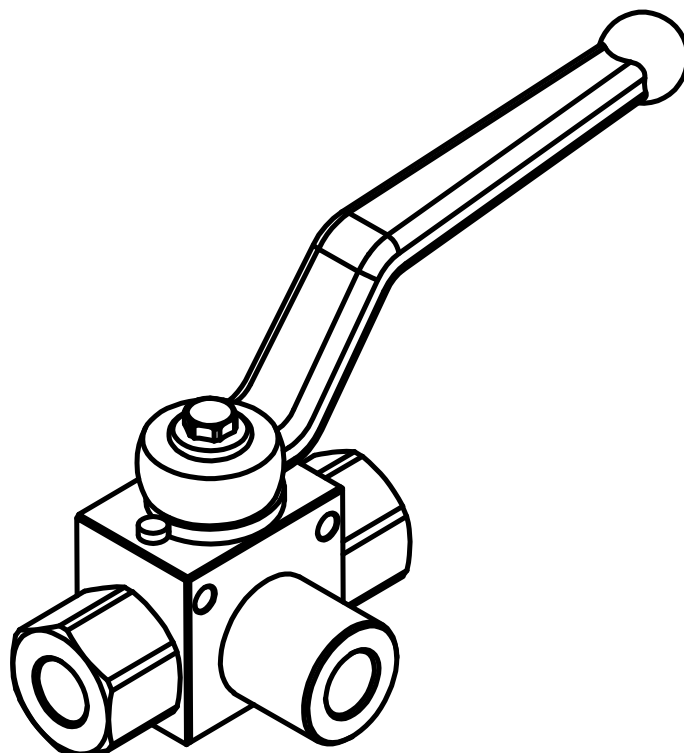

CARATTERISTICHE

Grandezza	1/4" - 3/8" - 1/2" - 3/4" - 1"
Portata min/max	Vedi tabella - See table
Pressione max. di picco	Vedi tabella - See table
Temperatura ambiente	-30°C + 50°C
Temperatura olio	-30°C + 80°C
Filtraggio consigliato	30 micron
Peso	Vedi tabella - See table

PERFORMANCE

Rated size
Min/max flow-rate
Max peak pressure
Room temperature
Oil temperature
Recommended filtration
Weight

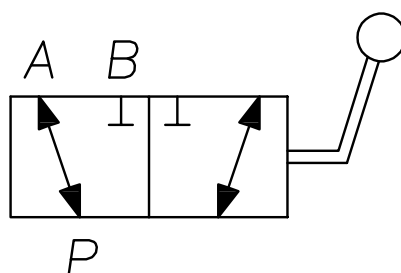

VALVOLE A SFERA 3 VIE ALTA PRESSIONE
HIGH PRESSURE 3-WAY BALL VALVES

VALVOLE A SFERA 3 VIE ALTA PRESSIONE HIGH PRESSURE 3-WAY BALL VALVES			
Funzione Function	Codice Ordinazione (con fori fissaggio) Ordering Code (with fixing holes)	Attacchi Port Size	Descrizione Description
	003.450.F00	1/4" GAS	RSAP3-V01
	003.451.F00	3/8" GAS	RSAP3-V02
	003.452.F00	1/2" GAS	RSAP3-V03
	003.453.F00	3/4" GAS	RSAP3-V04
	003.454.F00	1" GAS	RSAP3-V05

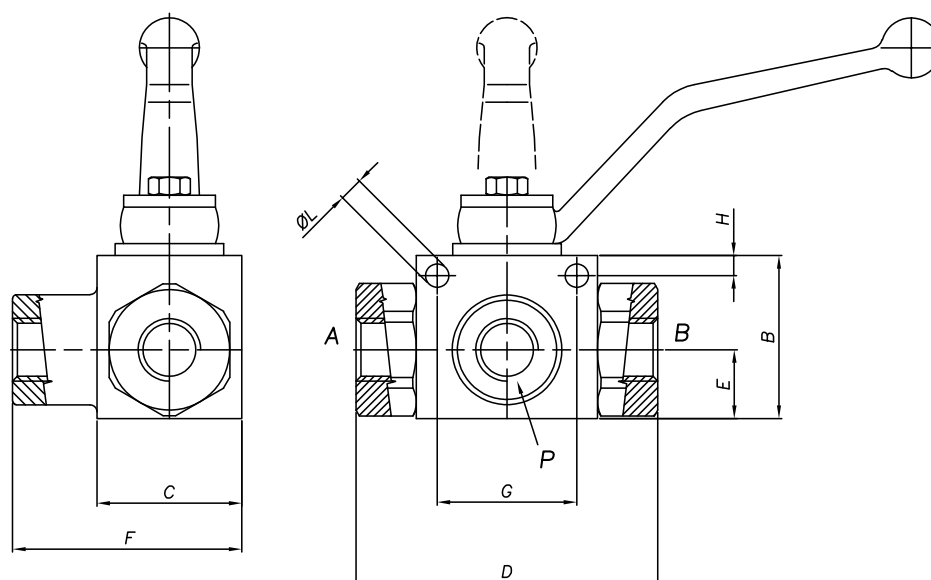

Attacchi Ports	B	C	D	E	F	G	H	ØL	Portata max Max flow	Pressione Max Max Pressure	Peso Weight
GAS	mm								l/min	bar	kg
1/4" GAS	35	26	69	14	39	32	4.8	4.5	15	500	0.41
3/8" GAS	40	32	72	16	47	32	5.8	5.3	30	500	0.55
1/2" GAS	45	35	83	18	52.5	39	6	6.5	60	500	0.75
3/4" GAS	58	50	93	23	69	49	6	6.5	80	315	1.60
1" GAS	65	57	115	28	82.5	51	7	8.5	125	315	2.30

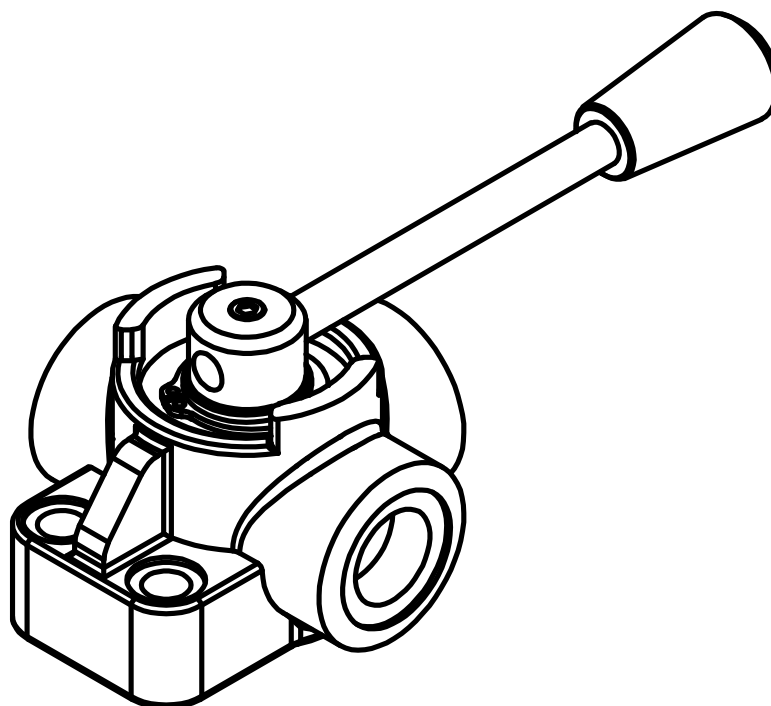

CARATTERISTICHE

Grandezza	3/8"-1/2"-3/4"-1"
Portata min/max	Vedi tabella - See table
Pressione max. di picco	Vedi tabella - See table
Temperatura ambiente	-30°C + 50°C
Temperatura olio	-30°C + 80°C
Filtraggio consigliato	30 micron
Peso	Vedi tabella - See table

PERFORMANCE

Rated size
Min/max flow-rate
Max peak pressure
Room temperature
Oil temperature
Recommended filtration
Weight

CENTRO CHIUSO
CLOSED CENTRE

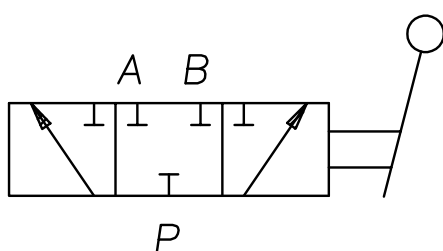

CENTRO APERTO
OPEN CENTRE

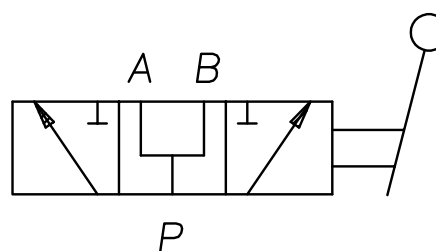

DEVIATORI DI FLUSSO A 3 VIE 3 - WAYS DIVERTER VALVES

DEVIATORI DI FLUSSO A 3 VIE 3-WAYS DIVERTER VALVES				
Funzione Function	Codice Ordinazione Ordering Code	Attacchi Port size	Schema Symbol	Descrizione Description
	003.400.000 003.401.000 003.402.000 003.403.000	3/8" GAS 1/2" GAS 3/4" GAS 1" GAS	CENTRO APERTO Open centre	DDF3V-02A DDF3V-03A DDF3V-04A DDF3V-05A
	003.406.000 003.407.000 003.408.000 003.409.000	3/8" GAS 1/2" GAS 3/4" GAS 1" GAS	CENTRO CHIUSO Closed centre	DDF3V-02C DDF3V-03C DDF3V-04C DDF3V-05C

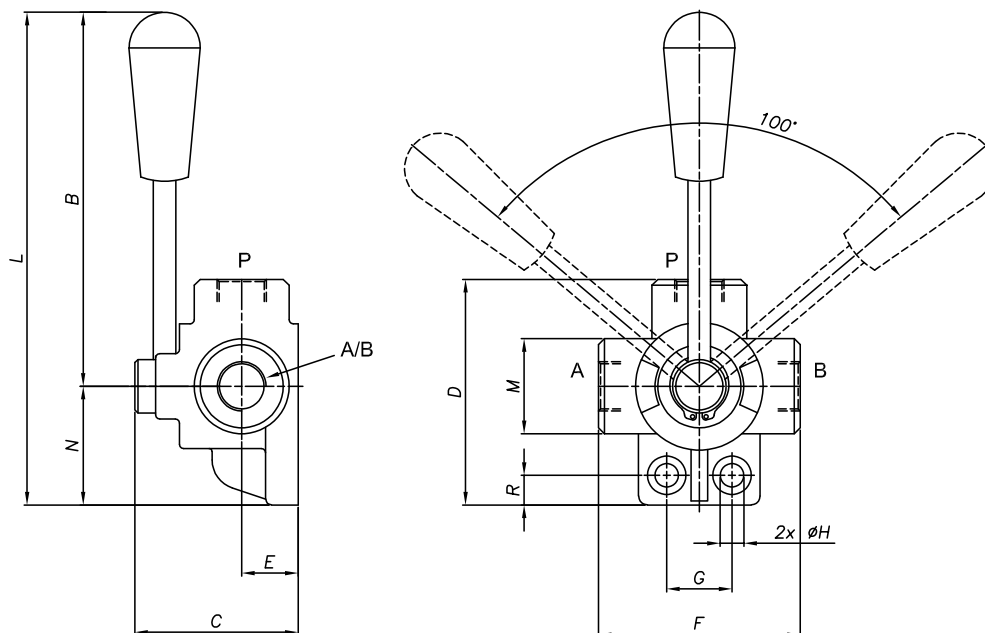

Attacchi Ports	B	C	D	E	F	G	ØH	L	M	N	R	Portata max Max flow	Pressione Max Max Pressure	Peso Weight
GAS	mm	mm	mm	mm	mm	mm	mm	mm	mm	mm	mm	l/min	bar	kg
3/8" GAS	128	62	77	21	73	24	8.5	169	35	41	14.5	60	300	0,90
1/2" GAS	128	70	96	25	85	32	10.5	180	40	52	17	90	250	1.45
3/4" GAS	125	80	100	28	90	32	10.5	180	45	55	14	120	220	1.85
1" GAS	140	90	115	32.5	96	32	11	207	56	67	17	200	220	2.50

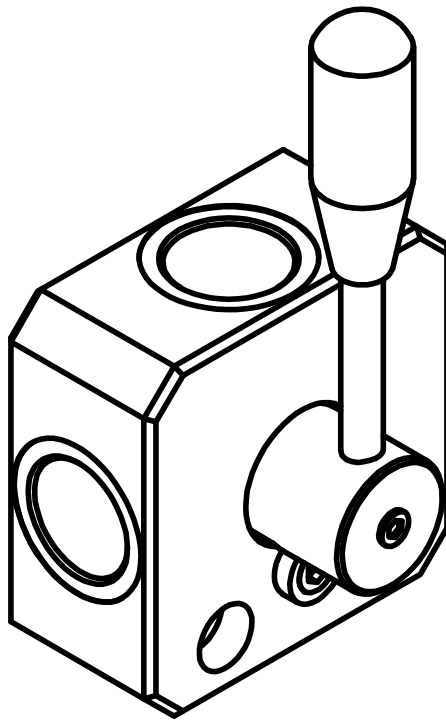

CARATTERISTICHE

Grandezza	3/8"-1/2"-3/4"-1"
Portata min/max	Vedi tabella - See table
Pressione max. di picco	Vedi tabella - See table
Temperatura ambiente	-30°C + 50°C
Temperatura olio	-30°C + 80°C
Filtraggio consigliato	30 micron
Peso	Vedi tabella - See table

PERFORMANCE

Rated size
Min/max flow-rate
Max peak pressure
Room temperature
Oil temperature
Recommended filtration
Weight

CENTRO CHIUSO
CLOSED CENTRE

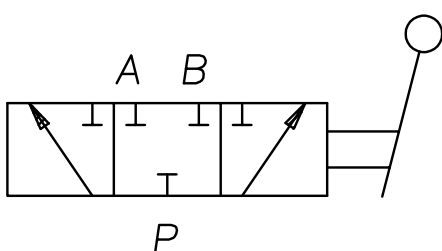

CENTRO APERTO
OPEN CENTRE

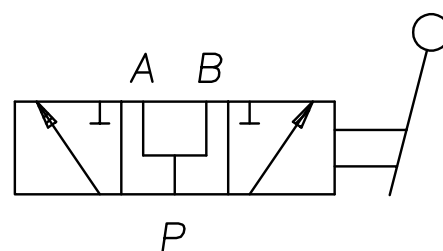

DEVIATORI DI FLUSSO A 3 VIE ALTA PRESSIONE
3-WAY DIVIDER VALVES HIGH PRESSURE

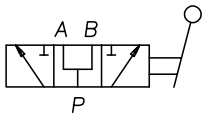
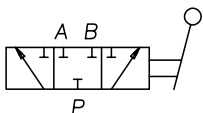
DEVIATORI DI FLUSSO A 3 VIE ALTA PRESSIONE 3-WAYS DIVERTER VALVES HIGH PRESSURE				
Funzione Function	Codice Ordinazione Ordering Code	Attacchi Port size	Schema Symbol	Descrizione Description
	003.412.000 003.413.000 003.414.000 003.415.000	3/8" GAS 1/2" GAS 3/4" GAS 1" GAS	CENTRO APERTO Open centre	DDF3VAP-02A DDF3VAP-03A DDF3VAP-04A DDF3VAP-05A
	003.416.000 003.417.000 003.418.000	3/8" GAS 1/2" GAS 3/4" GAS	CENTRO CHIUSO Closed centre	DDF3VAP-02C DDF3VAP-03C DDF3VAP-04C

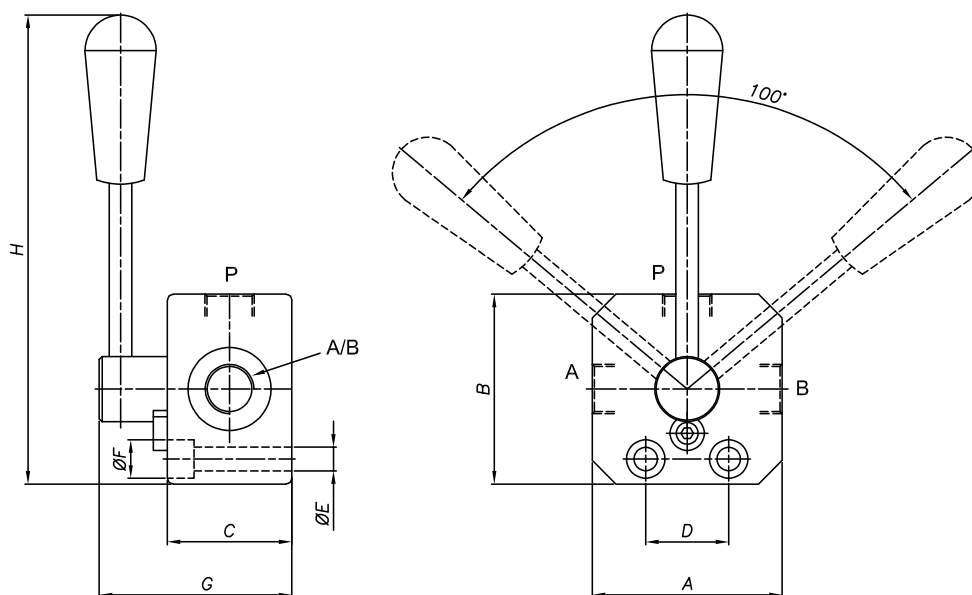

Attacchi Ports	A	B	C	D	ØE	ØF	G	H	Portata max Max flow	Pressione Max Max Pressure	Peso Weight
GAS	mm	mm	mm	mm	mm	mm	mm	mm	l/min	bar	kg
3/8" GAS	60	60	40	30	8.5	13.5	68	155	60	400	1.10
1/2" GAS	60	60	40	30	8.5	13.5	68	155	90	400	1.05
3/4" GAS	80	80	45	32	8.5	13.5	68	165	120	400	1.75
1" GAS (*)	100	100	48	37	8.5	13.5	78	187	250	350	3.50

(*)
centro aperto
open centre

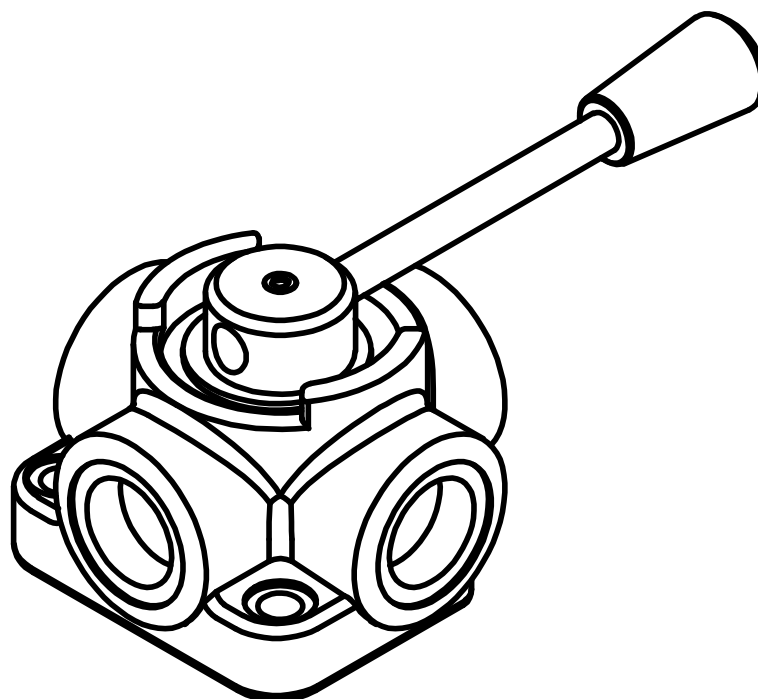

CARATTERISTICHE

Grandezza	3/8"-1/2"-3/4"
Portata min/max	Vedi tabella - See table
Pressione max. di picco	Vedi tabella - See table
Temperatura ambiente	-30°C + 50°C
Temperatura olio	-30°C + 80°C
Filtraggio consigliato	30 micron
Peso	Vedi tabella - See table

PERFORMANCE

Rated size
Min/max flow-rate
Max peak pressure
Room temperature
Oil temperature
Recommended filtration
Weight

CENTRO CHIUSO
CLOSED CENTRE

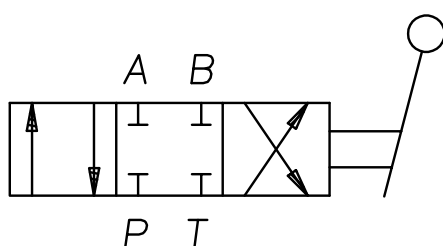

CENTRO APERTO
OPEN CENTRE

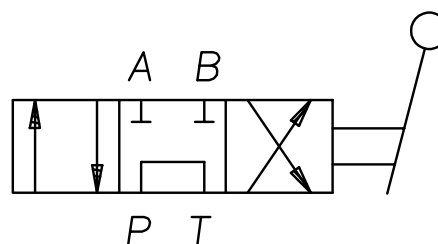

DEVIATORI DI FLUSSO A 4 VIE
4-WAY DIVERTER VALVES

DEVIATORI DI FLUSSO A 4 VIE 4-WAYS DIVERTER VALVES				
Funzione Function	Codice Ordine Ordering Code	Attacchi Port size	Schema Symbol	Descrizione Description
	003.420.000 003.421.000 003.422.000	3/8" GAS 1/2" GAS 3/4" GAS	CENTRO APERTO Open centre	IDF4V-02A IDF4V-03A IDF4V-04A
	003.423.000 003.424.000 003.425.000	3/8" GAS 1/2" GAS 3/4" GAS	CENTRO CHIUSO Closed centre	IDF4V-02C IDF4V-03C IDF4V-04C

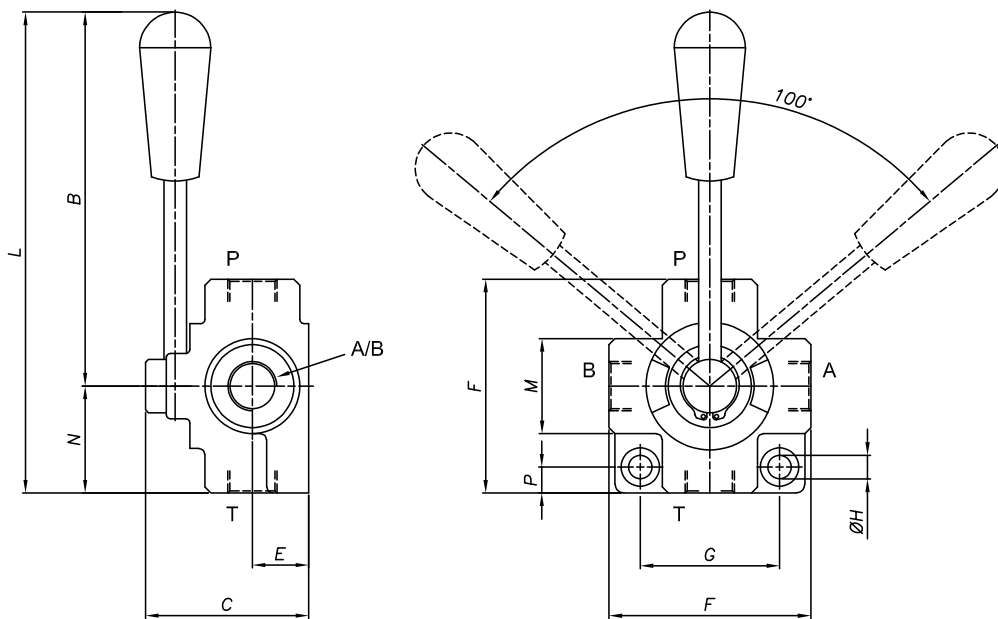

Attacchi Ports	B	C	E	F	G	ØH	L	M	N	P	Portata max Max flow	Pressione Max Max Pressure	Peso Weight
GAS	mm	mm	mm	mm	mm	mm	mm	mm	mm	mm	l/min	bar	kg
3/8" GAS	126	70	24	77	53.5	8.5	165	35	39	11	60	300	1.27
1/2" GAS	123	80	28	90	68	8.5	168	42	45	10	90	250	1.87
3/4" GAS	145	90	32	95	74	8.5	195	49	50	12	120	250	2.50

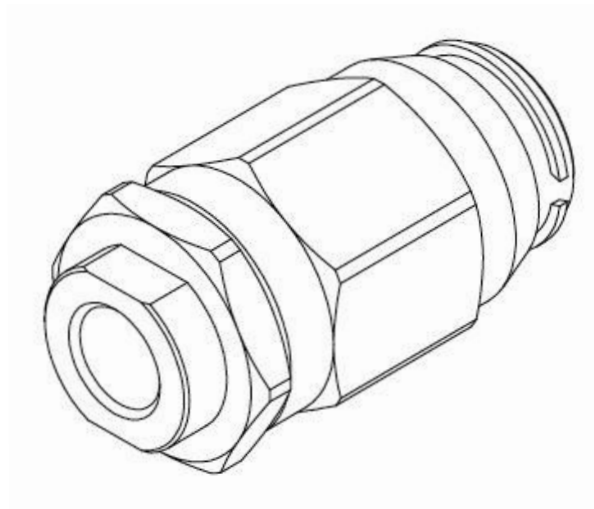

CARATTERISTICHE

Grandezza	1/4" - 3/8" - 1/2" - 3/4"
Portata min/max	15÷80 L/min
Pressione max. di picco	300÷350 bar
Temperatura ambiente	-30°C + 50°C
Temperatura olio	-30°C + 80°C
Filtraggio consigliato	30 micron
Peso	0.24÷1.1 kg

PERFORMANCE

Rated size
Min/max flow-rate
Max peak pressure
Room temperature
Oil temperature
Recommended filtration
Weight

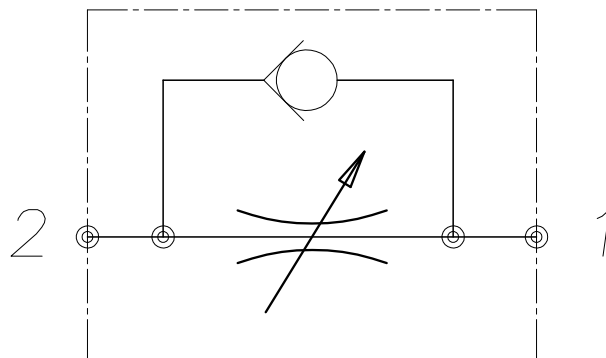

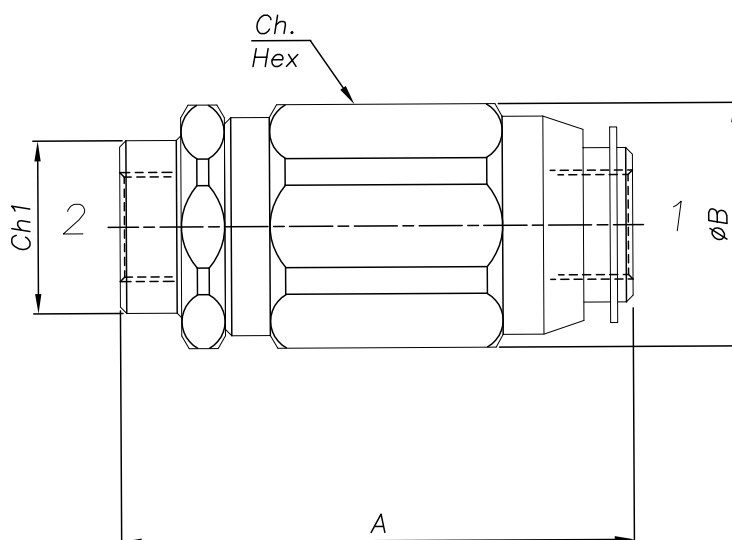

Attacchi Ports	Descrizione Description	Cod. Ordinazione Ordering Code	Portata Max Max Flow	Pressione Max Max Pressure	Peso Weight Kg	A	ØB	Ch	Ch 1
1/4" GAS	VST-UD-14	063	20	350	0.24	62	33.5	30	19
3/8" GAS	VST-UD-38	064	40	350	0.43	73	40.5	36	24
1/2" GAS	VST-UD-12	066	60	350	0.68	83	46	41	30
3/4" GAS	VST-UD-34	065	90	300	1.10	102	60.5	55	36

CODICE DI ORDINAZIONE HOW TO ORDER

004 063 0 0 0

Cod. Ordinazione / Ordering Code

063

064

066

065

VRFU-14/38/12/34/100

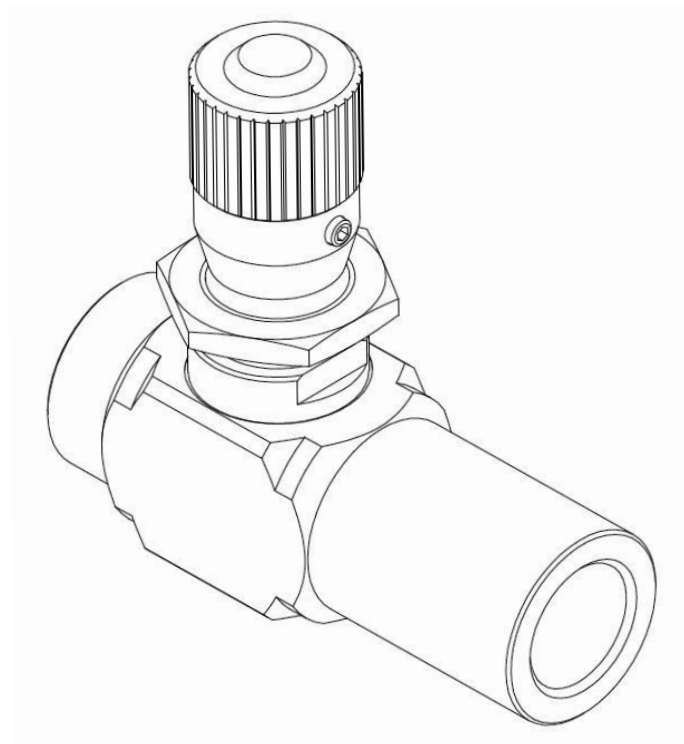

CARATTERISTICHE

Grandezza	1/4" - 3/8" - 1/2" - 3/4" - 1"
Portata min/max	15÷150 L/min
Pressione max. di picco	400 bar
Temperatura ambiente	-30°C + 50°C
Temperatura olio	-30°C + 80°C
Filtraggio consigliato	30 micron
Peso	0.4÷1.4 kg

PERFORMANCE

Rated size
Min/max flow-rate
Max peak pressure
Room temperature
Oil temperature
Recommended filtration
Weight

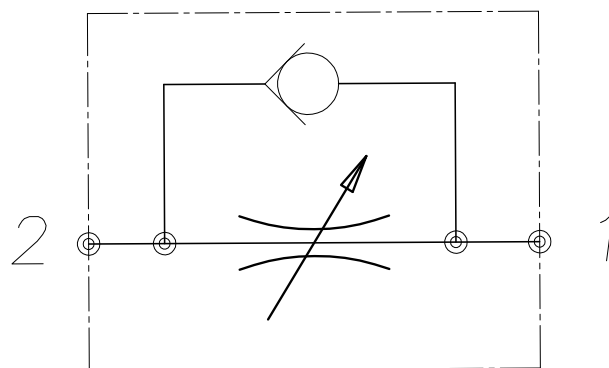

VALVOLE REGOLATRICI DI FLUSSO UNIDIREZIONALI UNIDIRECTIONAL FLOW CONTROL VALVES

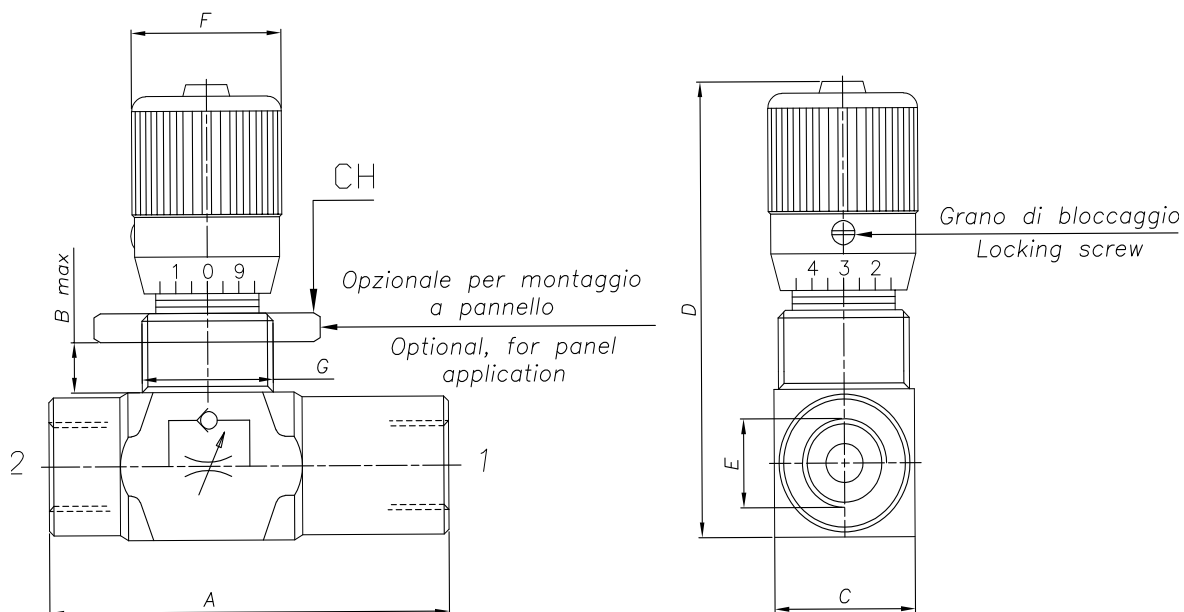

Attacchi (E) Ports (E)	Descrizione Description	Cod. Ordinazione Ordering Code	Peso Weight	A	B	C	D	F	G	CH	Portata Max Max Flow
1/4" GAS	VRFU-14	265	0.40	73	4.5	25	75	26	M20x1.5	30	15 L/min
3/8" GAS	VRFU-38	266	0.40	83	4.5	25	83	26	M20x1.5	30	30 L/min
1/2" GAS	VRFU-12	267	0.60	94	4.5	30	90	29	M20x1.5	30	50 L/min
3/4" GAS	VRFU-34	268	1.30	110	10	40	125	39.5	M35x1.5		80 L/min
1" GAS	VRFU-100	269	1.35	135	10	40	125	39.5	M35x1.5		150 L/min

CODICE DI ORDINAZIONE HOW TO ORDER

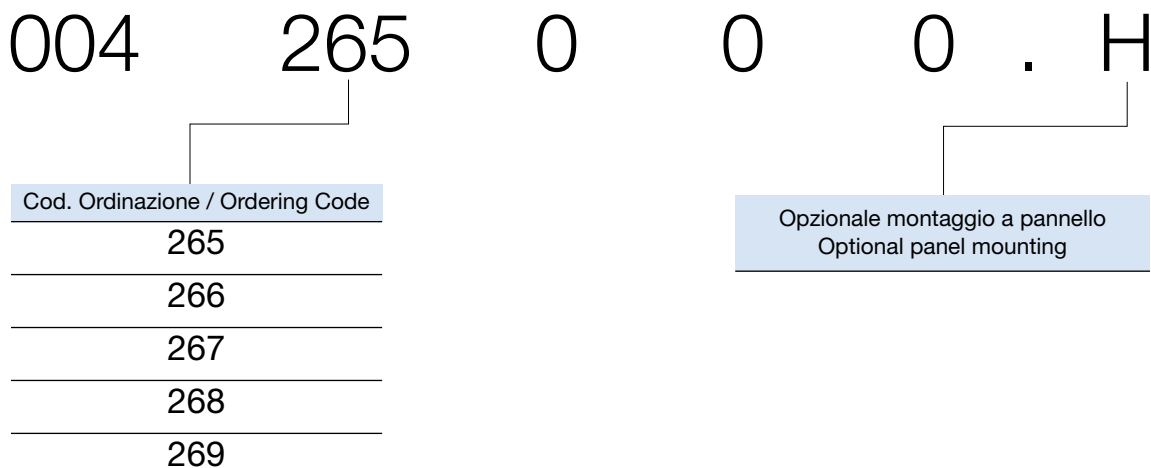

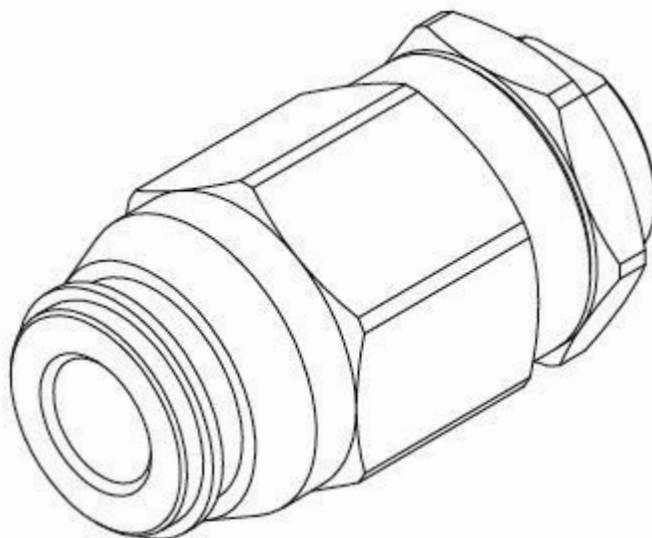

CARATTERISTICHE

Grandezza	1/4" - 3/8" - 1/2" - 3/4"
Portata min/max	15÷80 L/min
Pressione max. di picco	300÷350 bar
Temperatura ambiente	-30°C + 50°C
Temperatura olio	-30°C + 80°C
Filtraggio consigliato	30 micron
Peso	0.24÷1.1 kg

PERFORMANCE

Rated size
Min/max flow-rate
Max peak pressure
Room temperature
Oil temperature
Recommended filtration
Weight

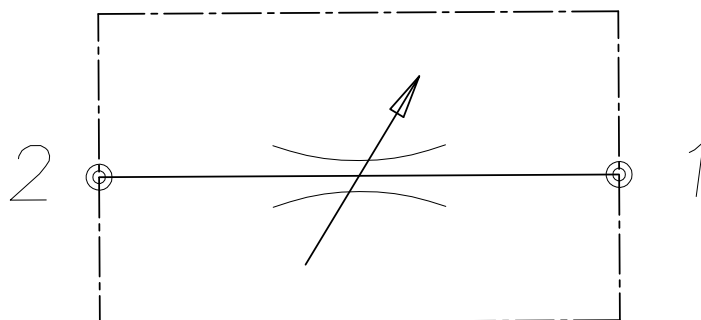

VALVOLE REGOLATRICI DI FLUSSO BIDIREZIONALI
BIDIRECTIONAL FLOW CONTROL VALVES

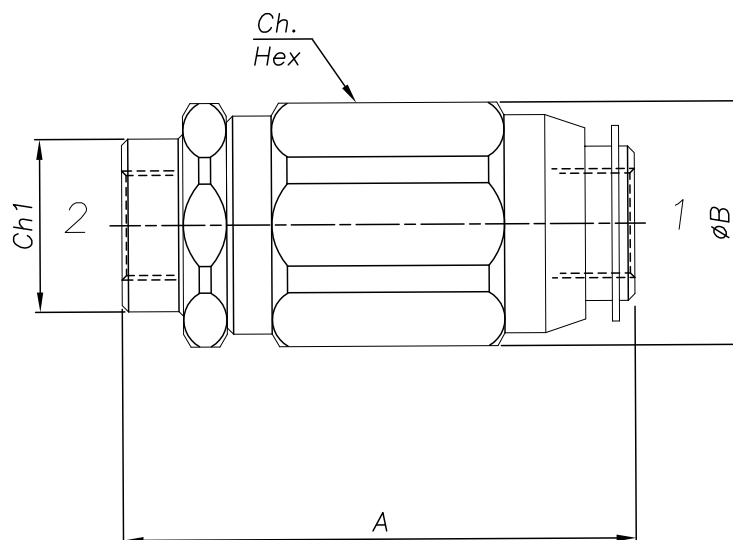

Attacchi Ports	Descrizione Description	Cod. Ordinazione Ordering Code	Portata Max Max Flow	Pressione Max Max Pressure	Peso Weight Kg	A	ØB	Ch	Ch 1
1/4" GAS	VST-BD-14	076	20	350	0.24	62	33.5	30	19
3/8" GAS	VST-BD-38	077	40	350	0.43	73	40.5	36	24
1/2" GAS	VST-BD-12	078	60	350	0.68	83	46	41	30
3/4" GAS	VST-BD-34	079	90	300	1.10	102	60.5	55	36

CODICE DI ORDINAZIONE
HOW TO ORDER

004 076 0 0 0

Cod. Ordinazione / Ordering Code

076

077

078

079

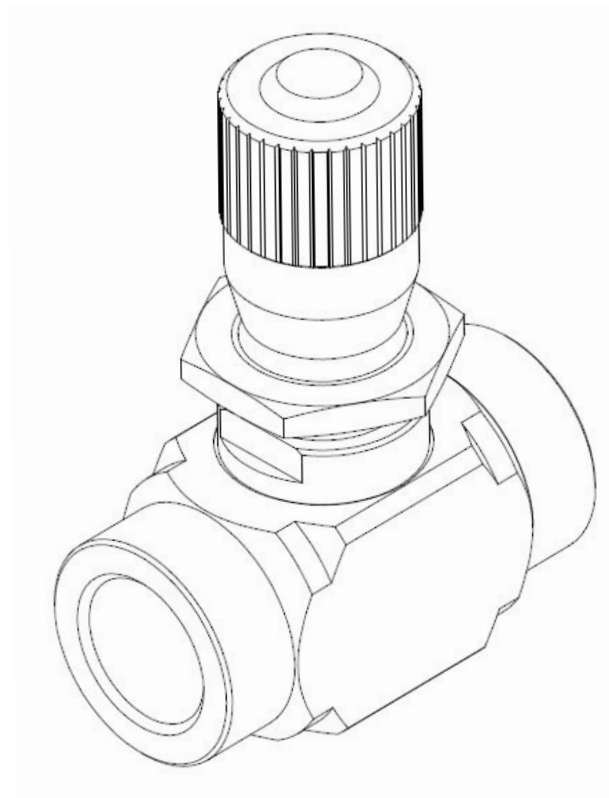

CARATTERISTICHE

Grandezza	1/4"- 3/8"-1/2"
Portata min/max	15÷50 L/min
Pressione max. di picco	350 bar
Temperatura ambiente	-30°C + 50°C
Temperatura olio	-30°C + 80°C
Filtraggio consigliato	30 micron
Peso	0.33÷0.45 kg

PERFORMANCE

Rated size
Min/max flow-rate
Max peak pressure
Room temperature
Oil temperature
Recommended filtration
Weight

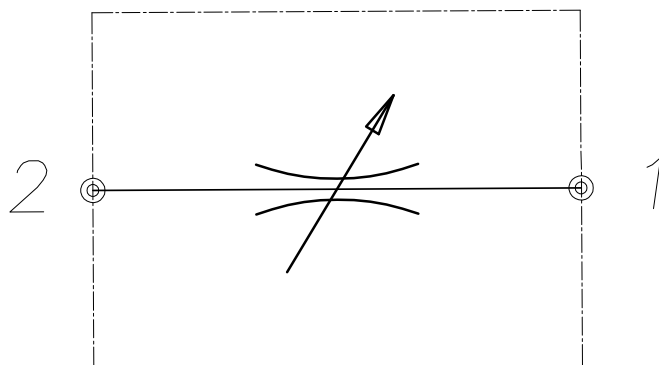

VALVOLE REGOLATRICI DI FLUSSO BIDIREZIONALI BIDIRECTIONAL FLOW CONTROL VALVES

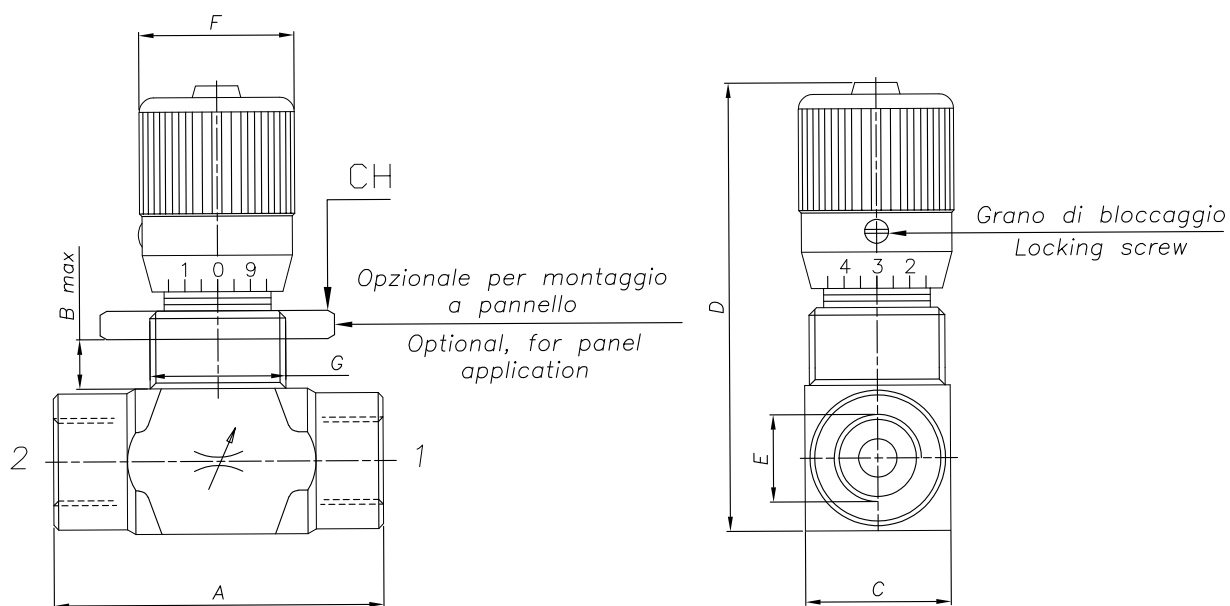

Attacchi (E) Ports (E)	Descrizione Description	Cod. Ordinazione Ordering Code	Peso Weight Kg	A	B	C	D	F	G	CH	Portata Max Max flow
1/4" GAS	VRFB-14	260	0.34	62	4.5	25	80	26	M20x1.5	30	15 L/min
3/8" GAS	VRFB-38	261	0.33	62	4.5	25	80	26	M20x1.5	30	30 L/min
1/2" GAS	VRFB-12	262	0.45	62	4.5	30	88	29	M20x1.5	30	50 L/min

CODICE DI ORDINAZIONE HOW TO ORDER

