



(4x) Ø8,5 PASS.
 □ Ø14 ∇ 10



(3.1)



VALVES

and integrated systems

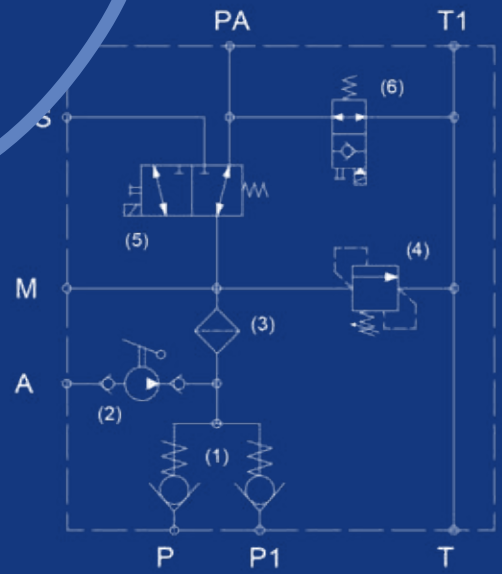
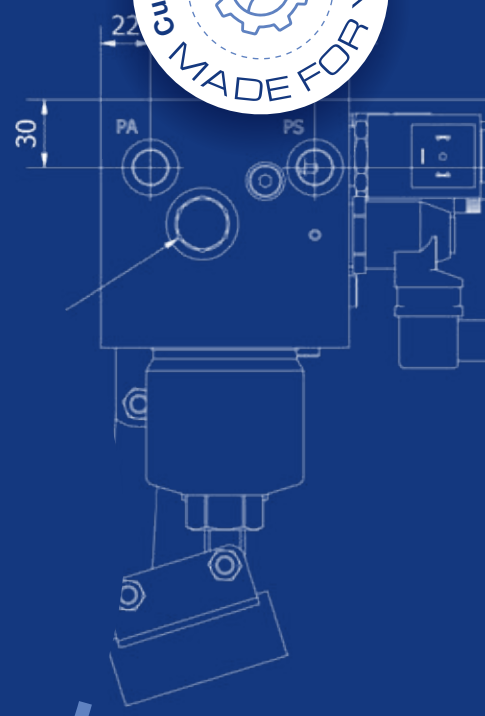
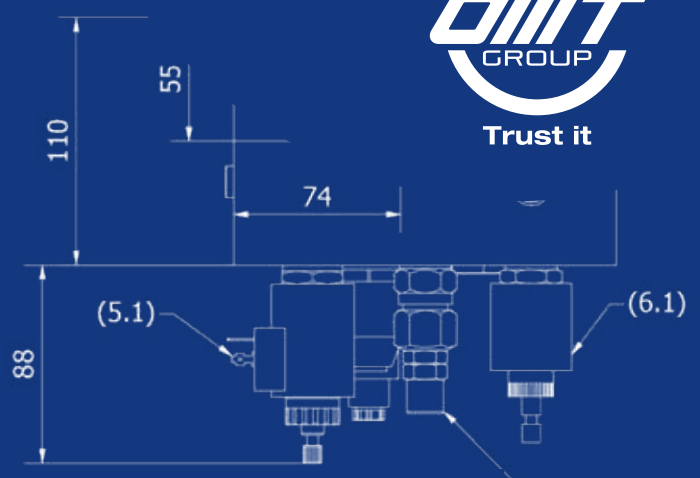

The value of DIFFERENCE

Standing out in a hyper-competitive market is the real challenge of today.

OMT Group supports you with customized solutions for your projects.

We have been designing and developing oil-hydraulic components tailored to our customers' needs for many years now.



WEAK POINT ANALYSIS



DESIGN



PRODUCTION

Three winning moves

Our products are based on a combination of expertise and technology.



Project

A team of technicians studies the characteristics of the **integrated unit** to meet your needs in every respect.



Production

Interconnected 4.0 machines and skilled workers work in synergy **to ensure the utmost precision.**



Test

By carrying out production entirely in-house, we are able to test the prototype during every stage of development and check that **it always meets the design criteria.**



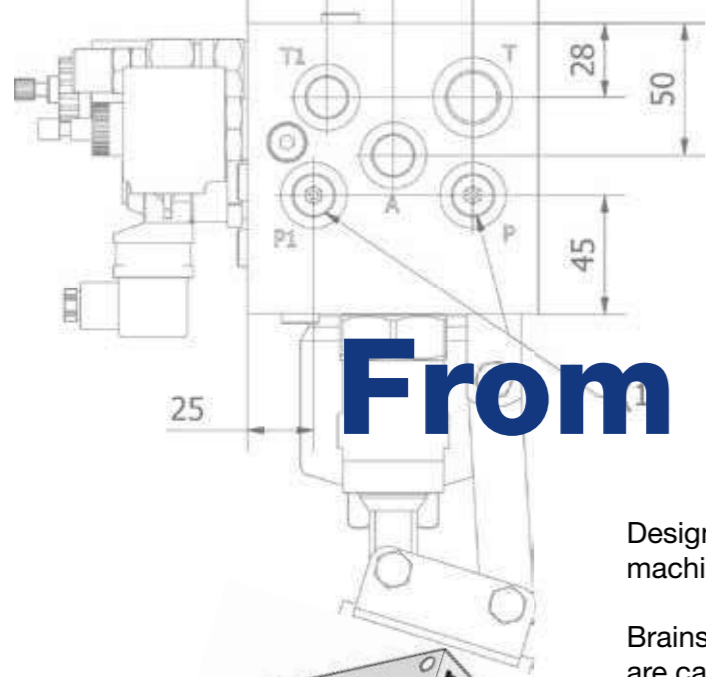

From the project ...to the SOLUTION

Design is the first step to creating machinery that meets your needs.

Brainstorming, analyses and plans are carried out to accomplish a goal: **the tailor-made component you desire.**

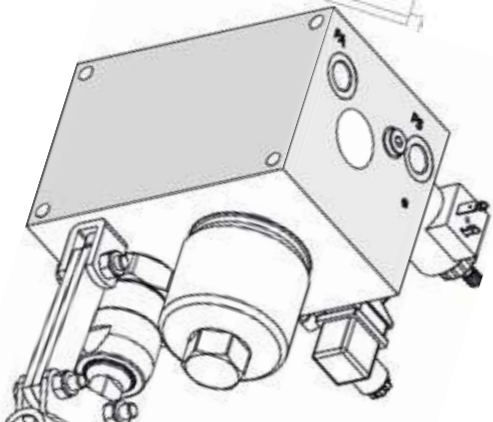

Integrated central control unit for the basic functions of a hydraulic system for mobile equipment such as aerial platforms.

During the development phase, we channel our efforts to guarantee you the best performance.



OMT Group has been very willing to find an answer to all our needs. In this instance, it grouped together three things we needed in a single block: oil filter, hand pump for emergency descent, and switching valve for the aerial part of the frame and they did the work in the best possible way.

Fiorenzo Flisi, President of Socage



HANDLING

Bespoke solutions to go beyond the STANDARD

1



Solution-oriented

Whatever your oil-hydraulic needs, we **will find the right solution** for you.

2



Careful and precise analysis

Careful analysis is carried out before the design phase, in order to understand how to best customize the component.

3



The project starts with you

You will be supported by a team of specialists which will prepare a project tailored to the technical needs of the application.

4



Towards development and beyond

We are always here to help: with an after-sales service that ends only upon delivery of the product and **once we are positive that everything is working as it should.**

CUSTOMIZED COMPONENTS
Made for you



CERTIFIED quality and performance



Our official certifications require careful analysis of the component, so we test it in our internal laboratories to assess its operation.

For more than 55 years we have adhered to our Quality Policy, delivering only certified products to customers.



UNI EN
ISO 9001



REACH
declaration



Customized integrated unit for the management of balancing, pressure control and sequence control functions of different actuators for a Hydracor Hydraulics mobile machine.



AGRICULTURE

Integrated unit for the management of pressure control, sequence control and exclusion functions for agricultural mobile machinery.



Ø63

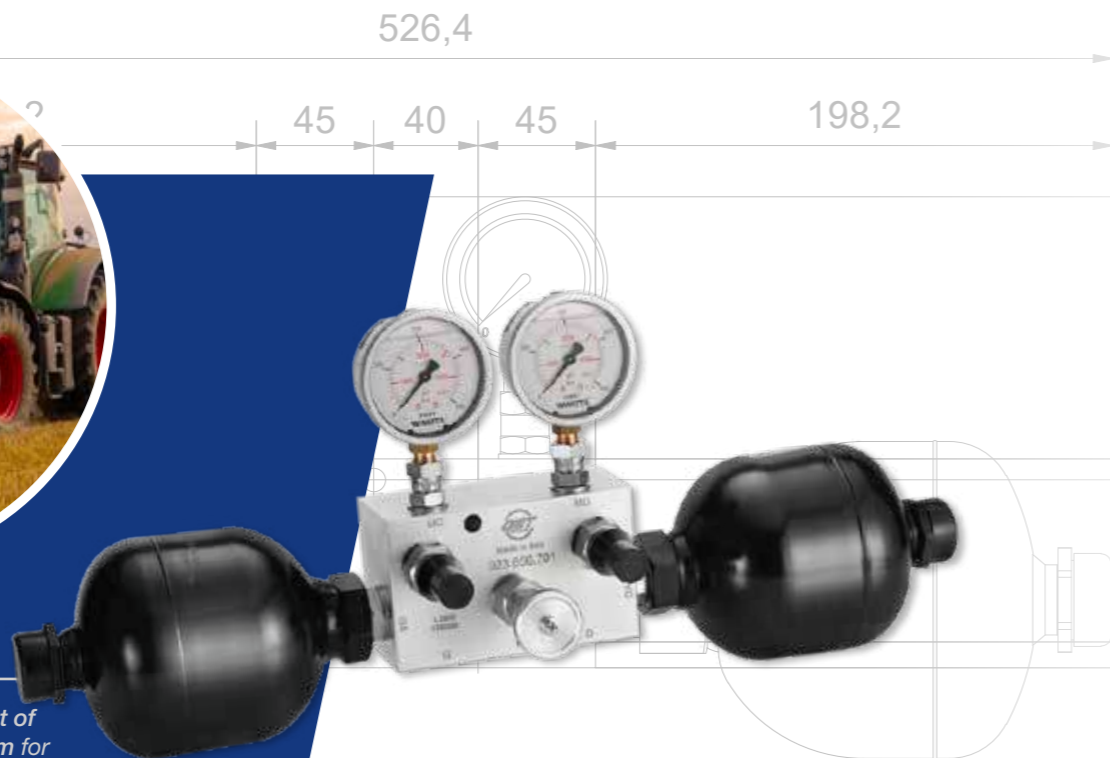
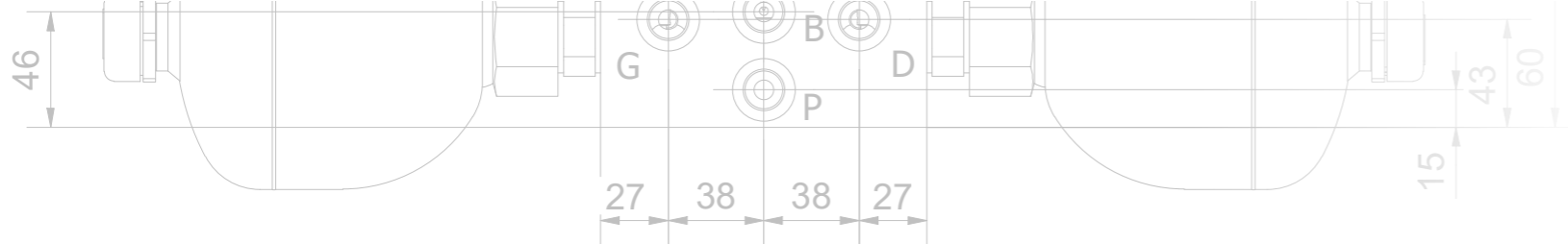

Integrated unit for the management of accumulators in a hydraulic system for farm equipment.

“Made for you” is the promise of those who, for over 55 years, have been offering **oil-dynamic solutions for high quality systems and machinery.**

Made For You represents our commitment to offering you the most effective customization possible.

We put at your disposal **a team of specialists to help you customize the components** for integration in your products and systems.

Customized solutions by the OMT Group, your choice beyond the standard.



Get more than just standard,
choose to be different
with the solutions MADE FOR YOU.



Trust it

OMT Group S.p.A.
Via Lombardia, 14
24040 Calvenzano (BG) - Italy
Tel.: +39 0363 86.03.11
Fax: +39 0363 33.56.20

 www.omtgroup.it

 omtgroup@omtgroup.it

    OMT Group

